

NEW

Radiometrix

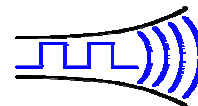

Hartcran House, 231 Kenton Lane, Harrow, HA3 8RP, England

Issue A, 25 February 2008

Tel: +44 (0) 20 8909 9595, Fax: +44 (0) 20 8909 2233

TR1M

Narrow Band FM Multi-channel VHF Transceiver

The TR1M narrow band multi channel transceiver module is intended as a general purpose VHF data communication unit. It is available on any frequency between 135 and 175MHz (in 3MHz bands) and delivers up to 100mW RF output. This transceiver offers a low power, reliable data link in an industry standard footprint. For added flexibility it shares a common pinout with the UHF TR2M module.



Figure 1: TR1M-151-5 VHF transceiver

Features

- ◆ Conforms to EN 300 220-3 and EN 301 489-3
- ◆ Any 3MHz band module from 135MHz to 175MHz available as factory tuned custom variant
- ◆ High performance double superhet, 128 channel PLL Synthesizer with TCXO
- ◆ Data rates up to 5 kbps for standard module
- ◆ Usable range over 1km (with 100mW variant)
- ◆ Fully screened
- ◆ Feature-rich interface (RSSI, automatic noise squelch, analogue and digital baseband)
- ◆ Incorporates a 1200baud dumb modem
- ◆ User configurable via RS232 interface
- ◆ Low power requirements

Applications

- ◆ Handheld terminals
- ◆ Heavy vehicle/machine remote controls
- ◆ EPOS equipment, barcode scanners
- ◆ Data loggers
- ◆ Industrial telemetry and telecommand
- ◆ In-building environmental monitoring and control
- ◆ High-end security and fire alarms
- ◆ Vehicle data up/download

Technical Summary

- ◆ Size: 59 x 38 x 12mm
- ◆ Custom variants from 135MHz to 175MHz on any 3MHz band (Available on the UK 173.2MHz - 173.325MHz 10mW band)
- ◆ 128 serial select or 8 parallel select channels
- ◆ Transmit power: +20dBm (100mW) nominal
- ◆ Supply range: 4.5V - 16V
- ◆ Current consumption: 110mA transmit (@100mW), 27mA receive
- ◆ Data bit rate: 5kbps max. (standard module)
- ◆ Receiver sensitivity: -118dBm (for 12 dB SINAD)

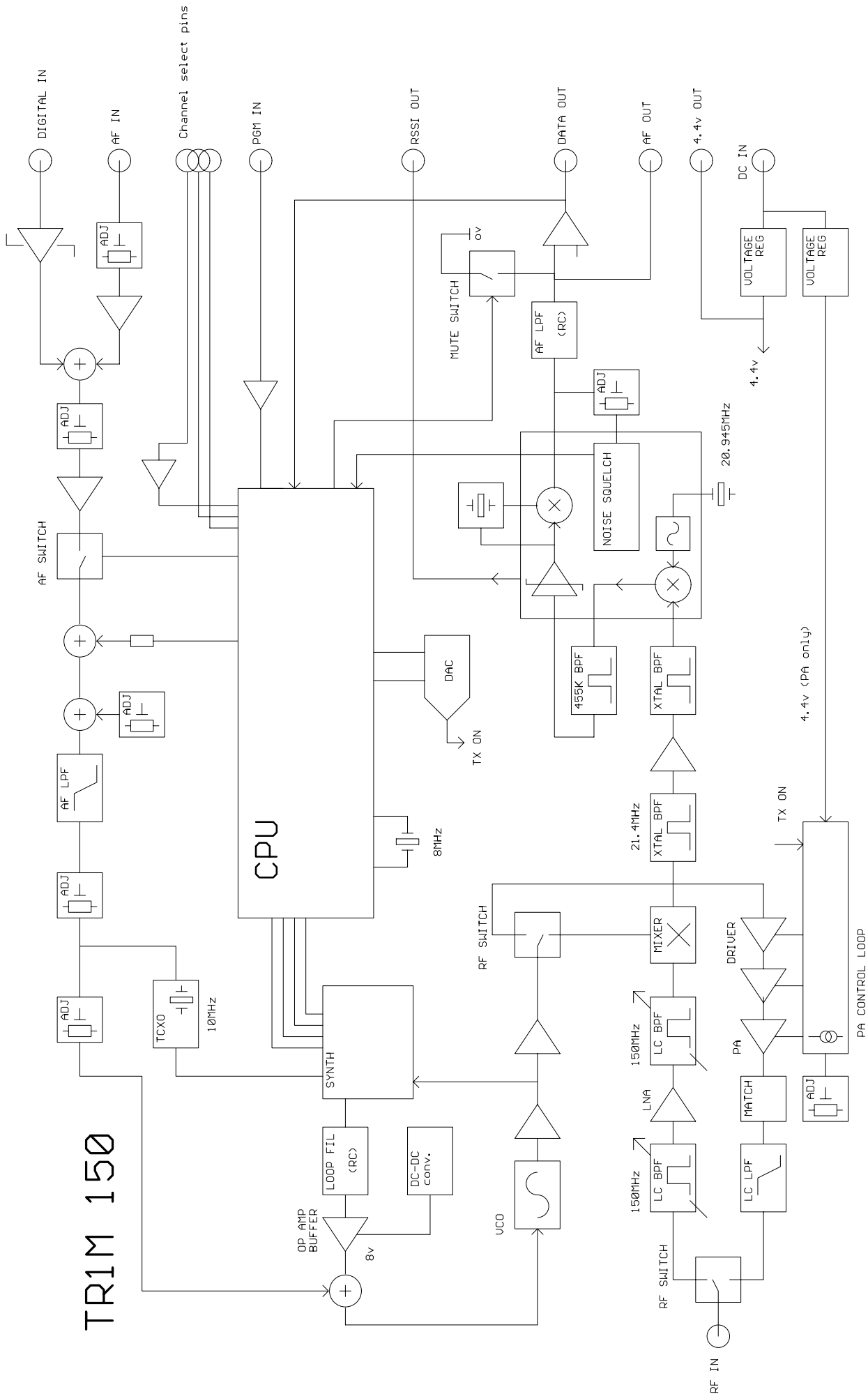

Figure 2: TRIM block diagram

- A: 1 Vcc
- A: 2 Gnd
- B: 1 RF Gnd
- B: 2 RF in
- B: 3 RF Gnd
- C: 1 TXE (MOD TX_ON)
- C: 2 TXD (MOD NC)
- C: 3 AF in (MOD NC)
- C: 4 RSSI
- C: 5 SQF (MOD NC)
- C: 6 AF out
- C: 7 RXD (MOD NC)
- C: 8 +4.4V out
- C: 9 0V
- C: 10 PGM
- C: 11 P1 (MOD TXD)
- C: 12 P2 (MOD RXD)
- C: 13 P3 (MOD NC)

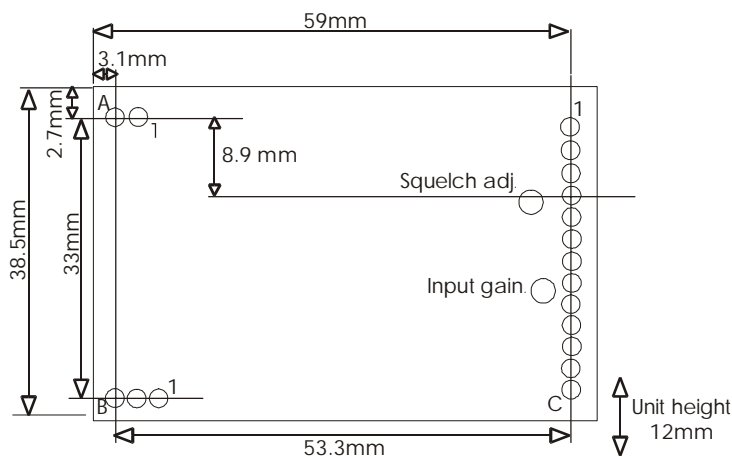

Figure 3: TR1M Footprint (Top) view

Pin Description - TR1M

Pins	Name	Function
A1	Vcc	4.5V-16V
A2	GND	Ground
B1	RF GND	RF ground
B2	RF	To the antenna
B3	RF GND	RF ground
C1	TXE (MOD TX_ON)	Transmitter Enable. Low = ON, Open = RX mode. Internal 10kΩ pull-up to 4V
C2	TXD (MOD NC)	DC coupled digital data input for 3-12V CMOS logic. Leave open if unused
C3	AF in (MOD NC)	50mV - 2.5v p-p AC coupled input. Variable gain. Factory set to 1V _{pk-pk} ±10% to keep distortion <1.5% and peak deviation >2.5kHz.
C4	RSSI	DC level between 0.5V and 2.5V. 60dB dynamic range
C5	SQF (MOD NC)	Noise operated carrier detect. Open collector. ON/low = no signal
C6	AF out	200mV _{pk-pk} audio. DC coupled, approx 1V bias. Muted by squelch
C7	RXD (MOD NC)	Open collector output of data slicer suitable for Biphase codes
C8	+4.4V out	Regulated DC supply. 75mA max. drain. Present if unit is powered
C9	0V	Ground
C10	PGM	Serial programming/configuration input at RS232 level
C11	P1 (MOD TXD)	Parallel frequency select inputs. Inverted logic, internal 10kΩ pullups to 4V
C12	P2 (MOD RXD)	
C13	P3 (MOD NC)	

Notes:

1. TR1M receiver section inverts the sense of the baseband stream, so a logical inversion is present between input of TX and output of RX.
2. Carrier detect on TR1M mutes the AF Out and RXD outputs. It can be factory disabled.
3. All the open collector outputs must be connected to Vcc/+4.4V out via a pull-up resistor.
4. The software incorporates a 1200baud dumb modem, compatible with that implemented in SMX1, UHX1, NBEK, TX1M, RX1M radios (11200 tones and format)
5. With 1200baud modem mode enabled, parallel selection of channel is unavailable as the P1-P3 lines are used for modem input/output operations.
6. PGM and MOD TXD (pin 10 and 11) tolerate true ±RS232 levels. No buffering is required.
7. For UK version the following channel assignment is supplied:

Channel	Frequency (MHz)
0	173.250
1	173.275
2	173.300
3	173.325
4 - 7	173.225 (only used for alarm applications)
8 - 127	173.325

TR1M serial configuration commands

2400 baud RS232. 8 bit data, no parity, 1 start bit, 1 or 2 stop bits, No flow control

SINGLE nnnnn	Set value of N for single channel operation
GOCHAN xx	Serial select of channel xx (0 to 127)
LOADMX xx	Set highest permitted (serial selected) channel xx (others default to ch0)
LOAD aa nnnnn	Set value of N for channel aa (channels 0 to 15)
LOADTB nnnnn	Set value of N for channel 16 (channels 17 to 127 then in sequence)
RVALUE rrrr	Enter value for R register
SETPAR	Channel selected by 3 bit parallel input (0 to 7). Disable modem
SETSER	Channel selected by most recent 'gochan' operation
SETMOD	Enable internal modem. Frequency selected by most recent 'gochan' or 'single'
OFFSET ooo	Set receive frequency offset (for 25KHz this is 856)
<cr>	Process entry
/	Clear all buffers

xx = channel number from 00 to 127

aa = two digit channel number from 00 to 15

nnnnn = synthesizer N register value, (up to 65535)

rrrr = synthesizer R register value, (up to 16383)

ooo = frequency offset

$$N = \frac{f_{RF}}{\left(\frac{10MHz}{R}\right)} = \frac{173.200MHz}{25kHz} = 6928$$

$$R = \frac{f_{TCXO}}{f_{channelspacing}} = \frac{10MHz}{25kHz}, \text{ So } R=400$$

Notes:

1. A pause of at least 50ms must be allowed between command strings (EEPROM programming time) SINGLE mode does not store the N value in EEPROM. Therefore the unit is inoperative after a power down until either another valid SINGLE command is received, or mode is changed by a GOCHAN, SETPAR or SETSER command. SINGLE mode is intended for frequency agile applications.
2. /SETPAR command should be issued at the end of channel programming to put the module back into parallel frequency select mode
3. In 173MHz band, channel 4- 7 (173.225MHz) is allocated specifically for fixed alarm and should not be used for general purpose applications.
4. User can modify the frequency table of 128 channels to any desired frequency by changing N, R values of synthesizer within $\pm 1.5MHz$ of factory set Channel 0 frequency subject to the Radio Regulatory Band Allocation in the country of intended use.
5. All other frequency, power, analogue input gain and automatic noise squelching adjustment will be treated as custom variants of the module to be set by factory.

Pin description of TR1M with Modem mode selected

The 'modem' mentioned is a 1200 baud RS232 semi-intelligent unit (Transmit keyed when valid serial data is present, so no separate TX control needed. Coding in the datastream also permits the receiver to ignore noise and only output valid serial data). This is a half duplex unit, so collisions between transmitted and received packets must be dealt with by the user.

Pins	Name	Function
1	MOD TX_ON	Open = normal modem operation. Low = constant TX (for test). 10k pullup to 4V
2	MOD NC	Leave open
3	MOD NC	Leave open
4	RSSI	DC level between 0.5V and 2.5V. 60dB dynamic range
5	MOD NC	Leave open
6	AF out	Modem tones or noise present
7	NC	Leave open
8	+4.4V out	Regulated DC supply. 75mA max. drain. Present if unit is powered
9	0V	Ground
10	PGM	Serial programming/configuration input at RS232 level
11	MOD TXD	RS232 data input (true). 10k pullup to 4V
12	MOD RXD	Inverted RS232 data out (to inverting buffer like MAX232)
13	CDE	Pull low to enable carrier detect on receive operation (not recommended)

TR1Ms on both ends should be configured to required operating frequency using GOCHAN command before starting to use the internal 1200 baud modem, because the P1-P3 pins will be used as Modem Data pins and the modem will operate on the last serially selected channel after SETMOD command is used to enable the Modem.

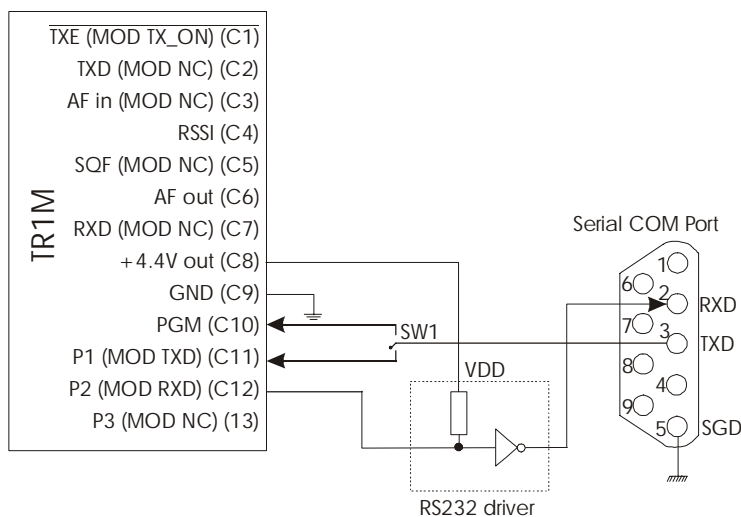

Figure 4: TR1M interfaced to PC serial port in modem mode

Note:

Baud rate used for Modem is half that of used for serial configuration. Attached RS232 devices should be set with the following:

1200bps, 8 Data bits, No Parity, 1/2 stop bits, no flow control

TXD (Pin 3) of a Serial Port can be switched from PGM (Pin C10) to MOD TXD (Pin C11) with no RS232 driver in between. However, MOD RXD (Pin C12) requires an RS232 line driver before it can be connected to RXD (pin 2) of a serial port. Some of the RS232 line drivers can be powered from the regulated +4.4V out (Pin C8).

Condensed specifications

Frequency Any 3MHz band from 135 - 175MHz
Frequency stability +/- 1.5kHz
Channel spacing 25kHz (12.5kHz by special order)
Number of channels 128 channels controlled via RS232 interface (8 parallel selected)

Supply *voltage* 4.5-16V
Current Transmit: 110mA nominal @ 100mW (55mA nominal @ 10mW)
 Receive: 27mA

Operating temperature -10 to +60 °C (Storage -30 to +70 °C)
 Size 59 x 38 x 12 mm
 Spurious radiations Compliant with ETSI EN 300 220-3 and EN 301 489-3

Interface

user 13pin 0.1" pitch molex
Power 2pin 0.1" pitch molex
RF 3pin 0.1" pitch molex
 Recommended PCB hole size 1.2mm (min.)

Intended approval ETSI Radio standard EN 300 220-3 and EMC standard EN 301 489-3

Transmitter	
Output power	+20dBm (100mW) ±1dB (factory adjustable 1-100mW)
TX on switching time	50 ms
Modulation type	FM, FSK (F1D, F3D)
TX modulation bandwidth	DC – 3kHz
Adjacent channel TX power	-37dBm
Inputs	analogue, data (CMOS/TTL compatible)
Receiver	
Sensitivity	-118dBm for 12dB SINAD
<i>image / spurious</i>	-70dB
<i>blocking</i>	-85dB
<i>adjacent channel</i>	<-65dB (Tested per. ETSI EN 301 489-3)
Outputs	RSSI, carrier detect, audio, data
Power on to valid audio (no noise mute)	28ms
Power on to valid audio (with noise mute)	45ms
Power on to stable data out (50:50 mark / space)	50ms (with or without mute)

Notes: 1. The data slicer cannot be depended upon for data waveform frequencies below 250Hz

2. When RX is on and a transmitter keys up, again a 50ms period is required to stabilise data output mark/space. i.e. allow at least 50ms of preamble

Application information

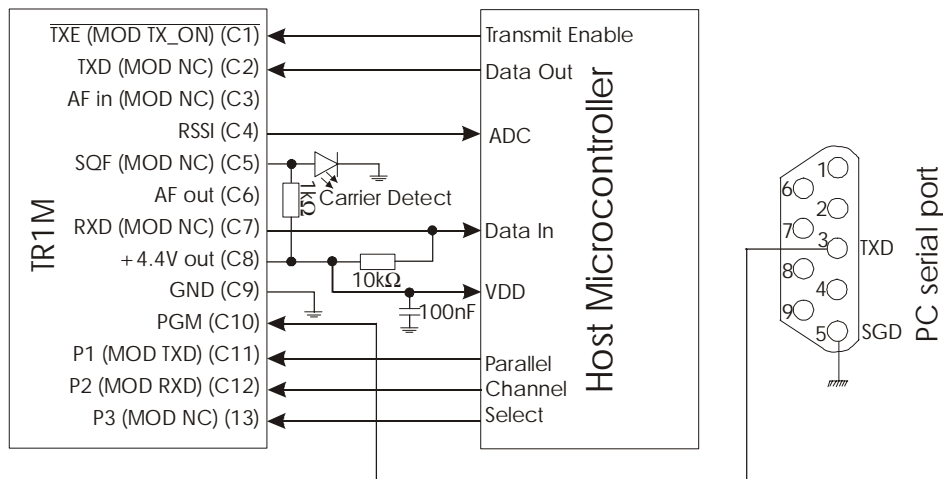

Figure 5: TR1M interfaced to host microcontroller and serial port for configuration

TR1M can be directly interfaced to a host microcontroller which can generally be powered by the regulated +4.4V output on pin 8 of TR1M. Three I/O pins on the microcontroller port can be assigned to select the first 8 channels on frequency table of the appropriate band for which the module is configured by pulling the P1-P3 pins low. Channel select pins of TR1M have internal pull-up to 4V supply rail, hence channel selection operate on inverted logic.

Digital Received Data Output (RXD) pin is an open collector output, which should be pulled-up to required voltage swing level (e.g. +4.4V or Vcc).

TR1M has an automatic noise squelching function which is activated when there is not any RF signal at detectable level on the channel or if the non-coherent noise like interference level is high enough to block any weak RF signal from being received. SQF is provided as an open-collector output for monitoring which should be pulled-up to required voltage swing level. SQF output will jump to pull-up voltage level if received RF signal level at the RF In/Out pin of the module is about 3dB below the level required to produce 12dB SINAD level on demodulated AF Output signal. SQF pin can be connected to an LED to act as a Carrier Detect indicator. Pull-up resistor value should be reduced (e.g. 1kΩ) according to the current requirement to produce satisfactory brightness on the LED used.

TR1M can be configured using any PC/Laptop/PDA having a serial port and modem/terminal program. TXD (pin 3) of DB9M connector can be directly wired to PGM (pin C10) of the TR1M and SGND (pin 5) of DB9M connector should be either connected to common ground or pin C9 of the TR1M.

The whole frequency/channel table is user reconfigurable to 128 channels within 3MHz band of supplied frequency subject to regulatory band limits.

Received Signal Strength

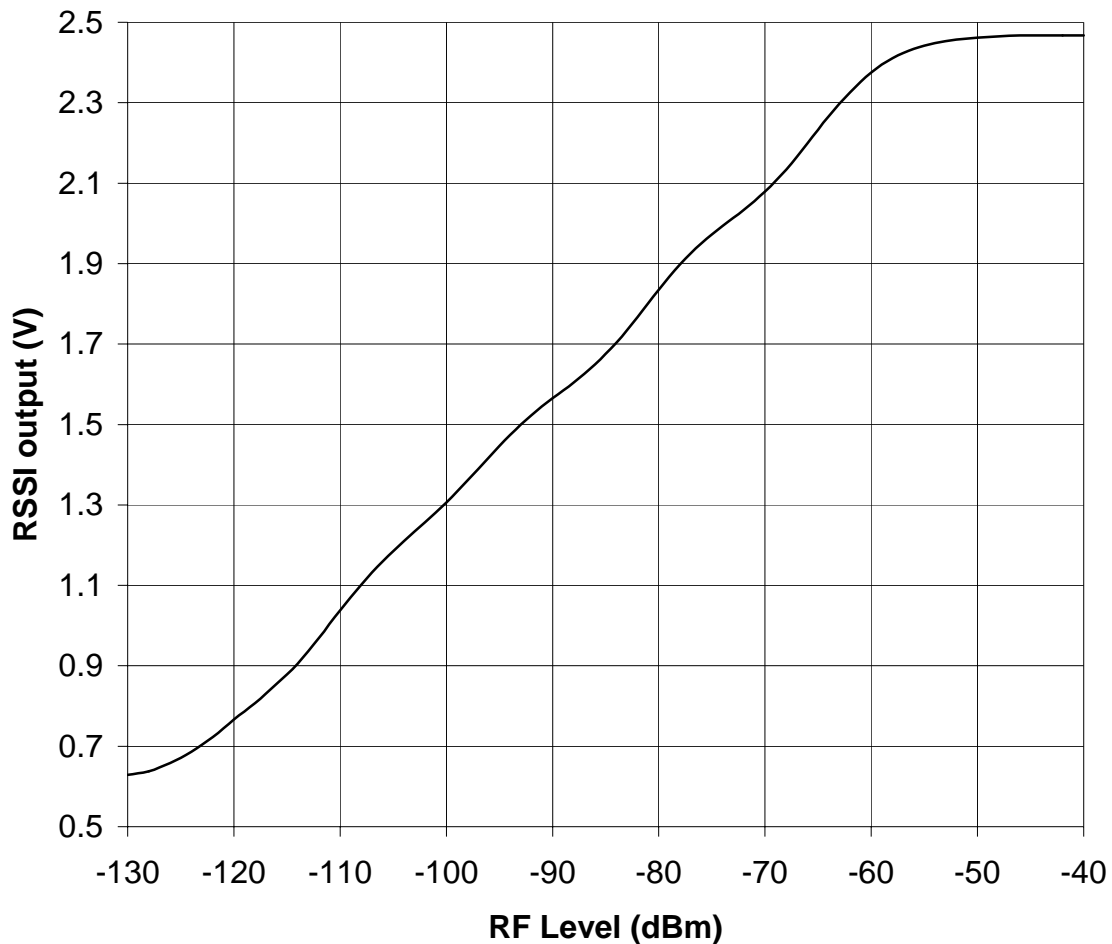

Figure 6: Typical RSSI voltage variation with respect to RF level at TR1M

If the microcontroller has a built-in Analogue to Digital Converter (ADC), the Received Signal Strength Indicator (RSSI) output voltage level can be read by the microcontroller to estimate its distance from transmitting TR1M unit or identify areas of weak signal reception.

RSSI can also be used to make a decision to switch to the second antenna in fixed installations within building where the probability of null-spots are higher.

Radiometrix Ltd

Hartcran House

231 Kenton Lane

Harrow, Middlesex

HA3 8RP

ENGLAND

Tel: +44 (0) 20 8909 9595

Fax: +44 (0) 20 8909 2233

sales@radiometrix.com

www.radiometrix.com

Copyright notice

This product data sheet is the original work and copyrighted property of Radiometrix Ltd. Reproduction in whole or in part must give clear acknowledgement to the copyright owner.

Limitation of liability

The information furnished by Radiometrix Ltd is believed to be accurate and reliable. Radiometrix Ltd reserves the right to make changes or improvements in the design, specification or manufacture of its subassembly products without notice. Radiometrix Ltd does not assume any liability arising from the application or use of any product or circuit described herein, nor for any infringements of patents or other rights of third parties which may result from the use of its products. This data sheet neither states nor implies warranty of any kind, including fitness for any particular application. These radio devices may be subject to radio interference and may not function as intended if interference is present. We do NOT recommend their use for life critical applications.

The Intrastat commodity code for all our modules is: 8542 6000

R&TTE Directive

After 7 April 2001 the manufacturer can only place finished product on the market under the provisions of the R&TTE Directive. Equipment within the scope of the R&TTE Directive may demonstrate compliance to the essential requirements specified in Article 3 of the Directive, as appropriate to the particular equipment.

Further details are available on The Office of Communications (Ofcom) web site:

<http://www.ofcom.org.uk/radiocomms/ifi/>

Information Requests

Ofcom

Riverside House

2a Southwark Bridge Road

London SE1 9HA

Tel: +44 (0)845 456 3000 or 020 7981 3040

Fax: +44 (0)20 7783 4033

information.requests@ofcom.org.uk

European Radiocommunications Office (ERO)

Peblingehus

Nansensgade 19

DK 1366 Copenhagen

Tel. +45 33896300

Fax +45 33896330

ero@ero.dk

www.ero.dk
