

## NBFM Direct Interface Multi Channel Transceiver

*The RMX2 is an ETSI EN 300 220-3 compliant UHF FM narrow band semi-duplex radio data module. It is a high performance transceiver designed for use in industrial applications requiring long range, high performance and reliability. The operating frequencies are available in the 315MHz, 433.05-434.79MHz European ISM band and 458.5-459.1MHz UK SRD band allocations.*



Figure 1: RMX2-433-10

### Features

- +10dBm (10mW) RF power, 3.0V @ 35mA operation
- Programmable RF channel
- Fast TX/RX switching time (5ms)
- Receiver sensitivity -119dBm
- Class one receiver performance
- ETSI EN 300 220-3, EN 301 489-3 compliant

RMX2 is a narrowband multichannel module with 25 kHz channel steps, but still achieves sub-10mS TX/RX switching speed, making it an ideal RF unit for inclusion in feedback systems.

The narrow band technique used in RMX2 enables high interference rejection and concurrent operation with multiple modules.

### Applications

#### Telemetry

- Water level monitor for rivers, dams, etc.
- Monitoring systems for environmental data such as temperature, humidity, etc.
- Transmission of measurement data (pressure, revolution, current, etc) to PC
- Security alarm monitoring

#### Telecontrol

- Industrial remote control systems
- Remote control systems for factory automation machines

**Evaluation platforms:** NBEK + RMX carrier

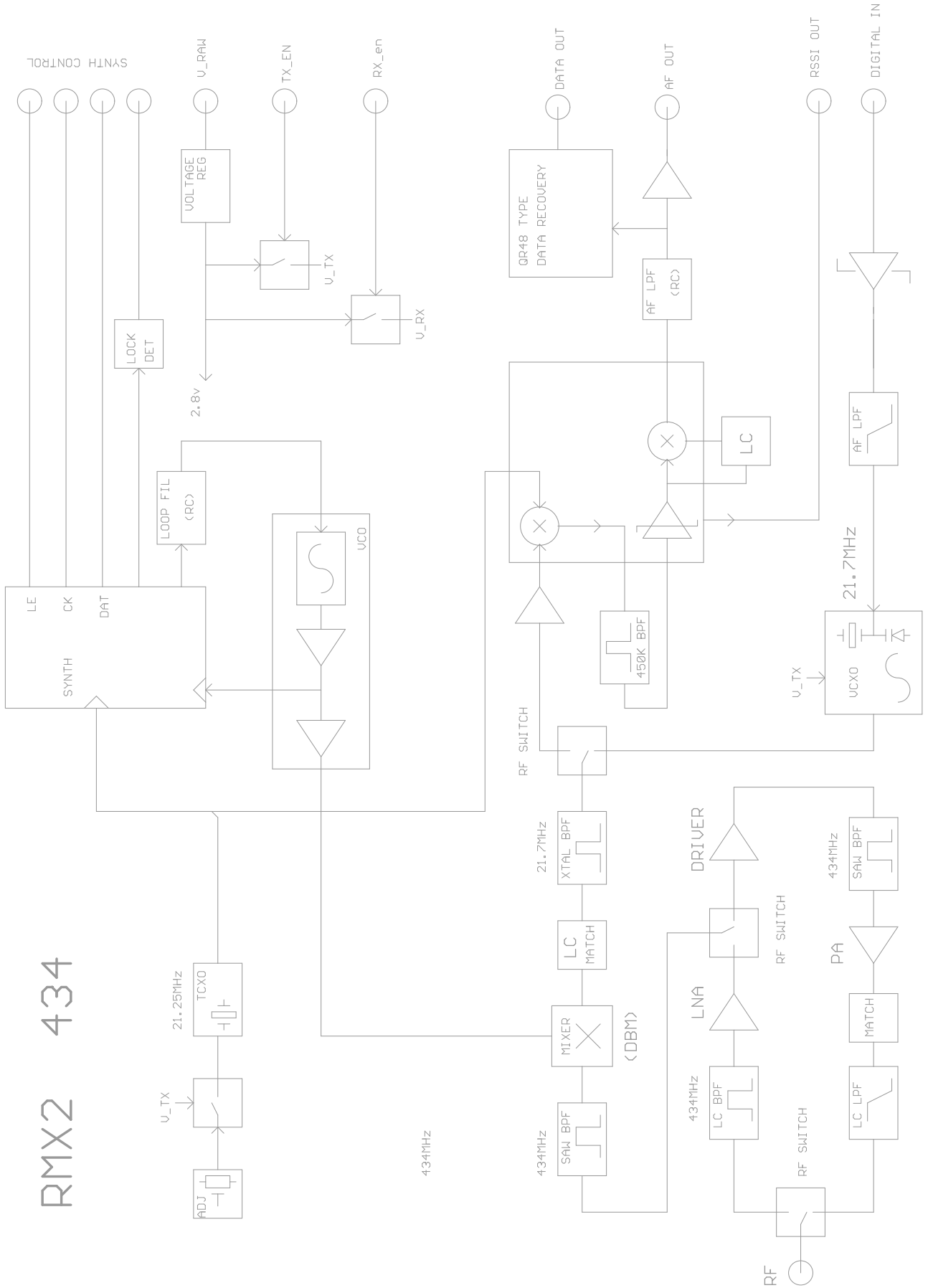
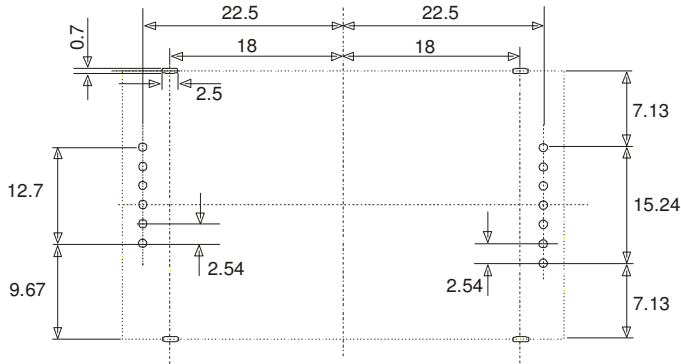
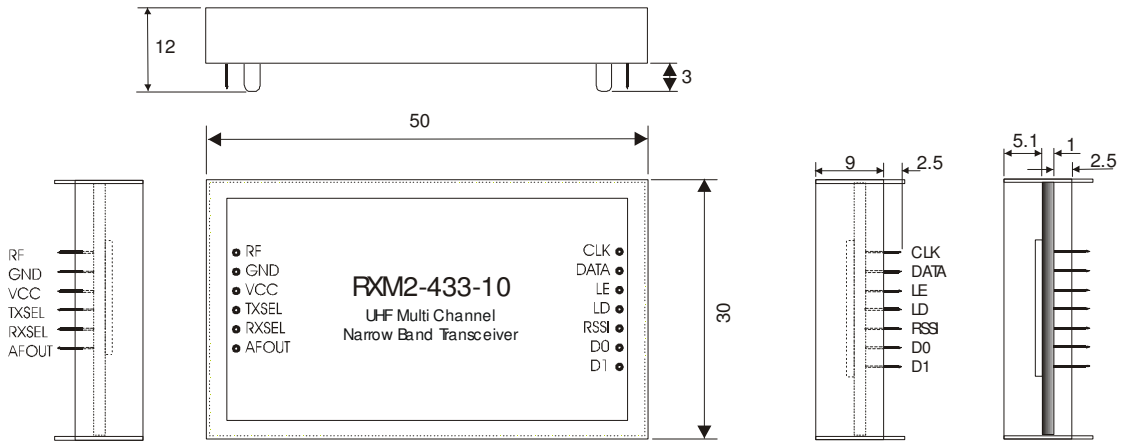

Figure 2: RMX2 block diagram



Reference hole position for PCB mounting (bottom view)

recommended PCB hole size: 1.2 mm

pin pitch: 2.54 mm

module footprint size: 30 x 50 mm

Figure 3: Pinouts and dimensions

## Condensed specifications

All ratings at 25 °C unless otherwise noted

| Parameter                           | Rating                                      | Conditions   |
|-------------------------------------|---|--|
| <b>General characteristics</b>      |   |  |
| Operating frequency range           | 315 - 315.375 MHz                           |  |
|                                     | 433.05 - 434.775 MHz                        | European ISM band (RMX2-433-10)                              |
|                                     | 458.5 - 459.1MHz                            | UK SRD allocation (RMX2-458-10)                              |
| Channel step                        | Programmable (PLL IC:<br>Fujitsu MB15E03SL) |  |
| Frequency stability                 | ±3ppm                                       | -20 to +70 °C  |
| Data rate                           | 9600 bps max                                | Input data pulse width: Min 104µs, Max 5ms                   |
| PLL reference frequency             | 21.25 MHz                                   |  |
| Operating voltage range             | 3 – 15 V                                    |  |
| Supply Current                      | 35mA (TX)<br>24mA (RX)                      |  |
| Operating temperature range         | - 20 to + 70 °C                             |  |
| Dimensions                          | 30 x 50 x 9 mm                              |  |
| <b>Transmitter section</b>          |   |  |
| RF output power                     | 10mW ±1dB                                   | At 434.0MHz / 458.7MHz, Antenna impedance 50Ω                |
| Deviation (Digital In)              | 2.4kHz ±0.3kHz                              | PN9, 9600 bps, LPF 20 kHz                                    |
| Deviation frequency characteristics | ± 3dB                                       | DC to 4800Hz   |
| TX S/N                              | -30dB                                       | 1kHz, Deviation = ±2.4kHz CCITT filter                       |
| Spurious emission                   | <-54dBm                                     | <1GHz, non-harmonic spuri                                    |
|                                     | <-40dBm                                     | 2nd and 3rd harmonics  |
| Adjacent channel leakage power      | -37dBm                                      | CH 25kHz, BW = 16kHz, PN9, 9600 bps                          |
| Total distortion and noise          | 30dB  | 1kHz, Deviation = ±2.4kHz, CCITT filter                      |
| Switching time RX to TX             | 5 - 10ms                                    | RX → TX <sup>*1</sup>  |
| Lock time                           | 30 – 40ms                                   | Free Run → TX <sup>*2</sup>                                  |
|                                     | 10 – 20ms                                   | 25kHz channel shift <sup>*3</sup>                            |
| <b>Receiver section</b>             |   |  |
| Receiver Sensitivity                | -119dBm (AF OUT)                            | 1kHz, Deviation ±2.4kHz, CCITT filter                        |
| Receiver S/N                        | 35dB  | 1kHz, Deviation ±2.4 kHz, CCITT filter,<br>RF level = -30dBm |
| Distortion                          | 5%  | 1kHz, Deviation ±2.4kHz, CCITT filter, RF level=-30dBm       |
| All spurious responses              | Better than 60dB                            | 2 signal method, Jamming signal = FM                         |
| Intermodulation                     | Better than 50dB                            | 2 signal method  |
| Adjacent channel selectivity        | 65dB  | 2 signal method, ± 25kHz<br>Jamming signal = FM              |
| Blocking                            | >84dBm                                      | ± 1, 2, 5, 10 MHz  |
| Switching time TX to RX             | 5 - 10 ms                                   | TX → RX <sup>*1</sup>  |
| Lock Time                           | 30 - 40 ms                                  | Free Run → RX <sup>*2</sup>                                  |
|                                     | 10 - 20 ms                                  | 25kHz channel shift <sup>*3</sup>                            |

### NOTES:

1. Time until TX frequency or 1st Local frequency reach a steady frequency ±1.5ppm
2. Time until TX frequency or 1st Local frequency reach a steady frequency ±1.5ppm after PLL setting data is set.
3. Time until TX frequency or 1st Local frequency reach a steady frequency ±1.5ppm after setting PLL setting data to change the frequency for 25kHz

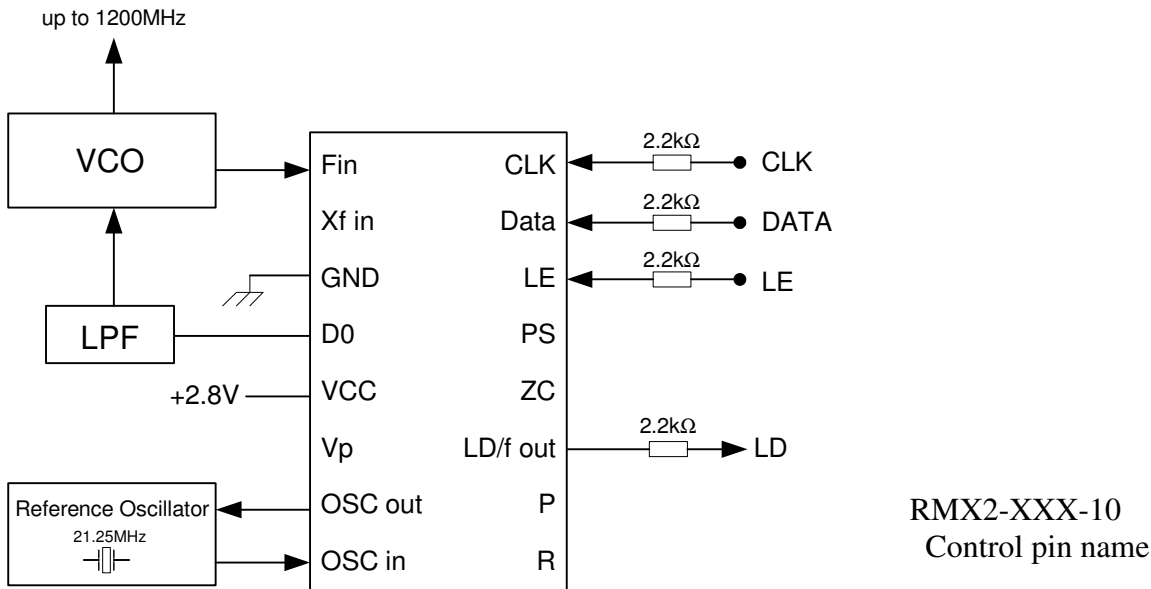

Figure 4: PLL IC Control

RMX2 has an internal PLL frequency synthesizer as shown in Figure 1. Channel frequency is set by loading data directly into the registers of the controlling IC over a simple, 3 wire serial bus (interface pins CLK, LE, DATA). Also RMX2 has a Lock Detect (LD) terminal that shows the lock status of the frequency. These signal lines are connected directly to the PLL IC through a 2.2kΩ resistor.

The interface voltage of RMX2 is 2.8 V, so the control voltage must be the same. RMX2 comes equipped with a Fujitsu MB15E03SL PLL IC. Please refer to the manual of the PLL IC.

<http://www.fujitsu.com/downloads/MICRO/fme/pll/e421359.pdf>

The following is a supplementary description related to operation with RMX2. In this description, the same names and terminology as in the PLL IC manual are used, so please read the manual beforehand.

### How to calculate the setting values for the PLL register

The PLL IC manual shows that the PLL frequency setting value is obtained with the following equation.

$$f_{VCO} = \frac{[(M \times N) + A] \times f_{osc}}{R} \quad N > M^2 \quad \text{Equation 1}$$

$f_{VCO}$ : Output frequency of external Voltage Controlled Oscillator (VCO)

N: Preset divide ratio of binary 11-bit programmable counter (3 to 2,047)

A: Preset divide ratio of binary 7-bit swallow counter ( $0 \leq A \leq 127$ )

$f_{osc}$ : Output frequency of the reference frequency oscillator

R: Preset divide ratio of binary 14-bit programmable reference counter (3 to 16,383)

M: Preset divide ratio of the dual modulus prescaler (64 or 128)

Because of the circuitry used in the RMX2, the frequency programmed into the PLL must be 21.7MHz below the desired channel frequency. There is no need to re-program when switching between transmit and receive modes.

Therefore the expected value of the frequency generated at VCO ( $f_{expect}$ ) is as below.

$$f_{VCO} = f_{expect} = (f_{ch} - 21.7\text{MHz}) \quad \text{Equation 2}$$

The PLL generates channel frequencies as multiples of a 'comparison' frequency. This phase comparison frequency ( $f_{comp}$ ) is made by dividing the frequency input to the PLL from the reference oscillator by reference counter R. The RMX2 uses a 21.25 MHz TCXO for the reference clock  $f_{osc}$ .  $f_{comp}$  can be either 12.5kHz or 25 kHz.

The above equation 1 results in the following with  $n = M \times N + A$ , where "n" is the number for division.

$$f_{VCO} = n \times f_{comp} \quad \text{Equation 3}$$

$$n = \frac{f_{VCO}}{f_{comp}} \quad \text{note: } f_{comp} = \frac{f_{osc}}{R} \quad \text{Equation 4}$$

Also, this PLL IC operates with the following R, N, A and M relational expressions.

$$R = \frac{f_{osc}}{f_{comp}} \quad \text{Equation 5}$$

$$N = INT\left(\frac{n}{M}\right) \quad \text{INT: Integer portion of a division} \quad \text{Equation 6}$$

$$A = n - (M \times N) \quad \text{Equation 7}$$

As an example, the setting value of RF channel frequency  $f_{ch}$  434.6750MHz can be calculated as below.

|             |                           |                                 |
|-------------|---------------------------|---------------------------------|
| Conditions: | Channel center frequency: | $f_{ch} = 434.6750\text{MHz}$   |
| Constant:   | Offset frequency:         | $f_{offset} = 21.7 \text{ MHz}$ |
| Constant:   | Reference frequency:      | $f_{osc} = 21.25 \text{ MHz}$   |

Set 25 kHz for Phase Comparison Frequency  $f_{comp}$  and 64 for Prescaler value M

The frequency of VCO will be:

$$f_{vco} = f_{expect} = f_{ch} - f_{offset} = 434.675 - 21.7 = 412.975\text{MHz}$$

Dividing value "n" is derived from Equation 4

$$n = f_{vco} / f_{comp} = 412.975\text{MHz} / 25\text{kHz} = 16519$$

Value "R" of the Reference Counter is derived from Equation 5.

$$R = f_{osc} / f_{comp} = 21.25\text{MHz} / 25\text{kHz} = 850$$

Value "N" of the programmable counter is derived from Equation 6.

$$N = INT(n/M) = INT(16519/64) = 258$$

Value "A" of the swallow counter is derived from Equation 7.

$$A = n - (M \times N) = 16519 - 64 \times 258 = 7$$

The frequency of RMX2 is locked at a centre frequency  $f_{ch}$  by inputting the PLL setting values N, A and R obtained with the above equations as serial data. The above calculations are the same for the other frequencies.

### Method of serial data input to the PLL

After the RF channel table plan is decided, the data needs to be allocated to the ROM table and read from there or calculated with the software.

Together with this setting data, operation bits that decide operation of the PLL must be sent to the PLL. The operation bits for setting the PLL are as follows. These values are placed at the head of the reference counter value and are sent to the PLL.

CS: Charge pump current select bit

CS = 0       $\pm 1.5 \text{ mA}$  select      VCO is optimised to  $\pm 1.5 \text{ mA}$

LDS: LD/fout output setting bit

LDS = 0      LD select      Hardware is set to LD output

FC: Phase control bit for the phase comparator

FC = 1      Hardware operates at this phase

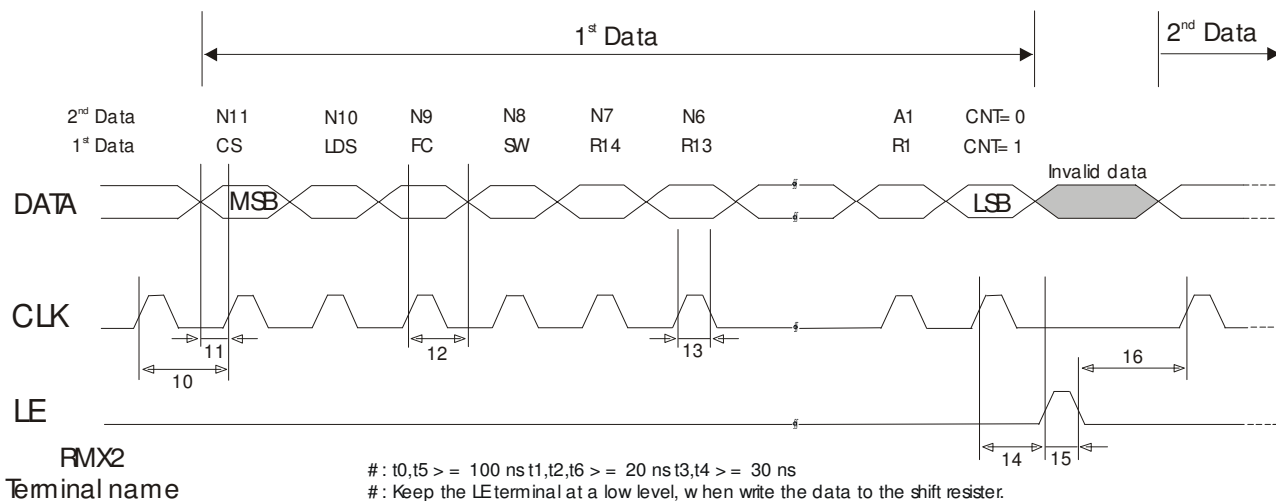

Figure 5: PLL IC programming timing diagram

The PLL IC, which operates as shown in the block diagram in the manual, shifts the data to the 19-bit shift register and then transfers it to the respective latch (counter, register) by judging the CNT control bit value input at the end.

- CLK [Clock]: Data is shifted into the shift register on the rising edge of this clock.
- LE [Load Enable]: Data in the 19-bit shift register is transferred to respective latches on the rising edge of the clock. The data is transferred to a latch according to the control bit CNT value.
- Data [Serial Data]: You can perform either reference counter setup or programmable counter setup first.

## TIMING CHART

Control timing in a typical application is shown in Figure 3.

Initialisation of the radio is performed following power-up and successful reset of the controlling CPU. The FET switches controlling the radio module systems (controlled by RXSEL and TXSEL) must be set to inactive (pin high or floating) to avoid unwanted emissions.

The power supply to the radio module is then turned on. When the radio module is first powered, the PLL internal registers are not yet set to meaningful values, and the VCO circuit will be unstable. Data transmission and reception is only possible 40 ms after the first set up data is sent to the PLL. Subsequent 'channel change' re-programming only takes 20 ms before data can be handled.

Changing channels must be carried out in the receive mode. If switching is performed in transmission mode, unwanted interference will be generated.

If the module is switched to the receive mode when operating in the same channel, (a new PLL setting is not necessary) it can receive data within 5 ms of switching<sup>\*1</sup>. For data transmission, if the RF channel to be used for transmission is set while still in receiving mode, data can be sent at 5 ms after the radio module is switched from reception to transmission<sup>\*2</sup>.

Check that the Lock Detect signal is "high" 20 ms after the channel is changed. In some cases the Lock Detect signal becomes unstable before the lock is correctly detected, so it is necessary to note if processing of the signal is interrupted.

- \*1: DC offset may occur due to frequency drift caused by ambient temperature change. Customers are urged to verify operation at low temperature and initial their timing.
- \*2: Sending '10101.....' preamble just after switching to transmission mode enables smoother operation of the data extraction circuit used by the receiver.  
For 9600 bps, a preamble of '11001100' is effective.  
Recommended preamble length:  
-10 °C - +55 °C: 7 ms  
-20 °C - +65 °C (for operation exceeding the above range): 15 ms

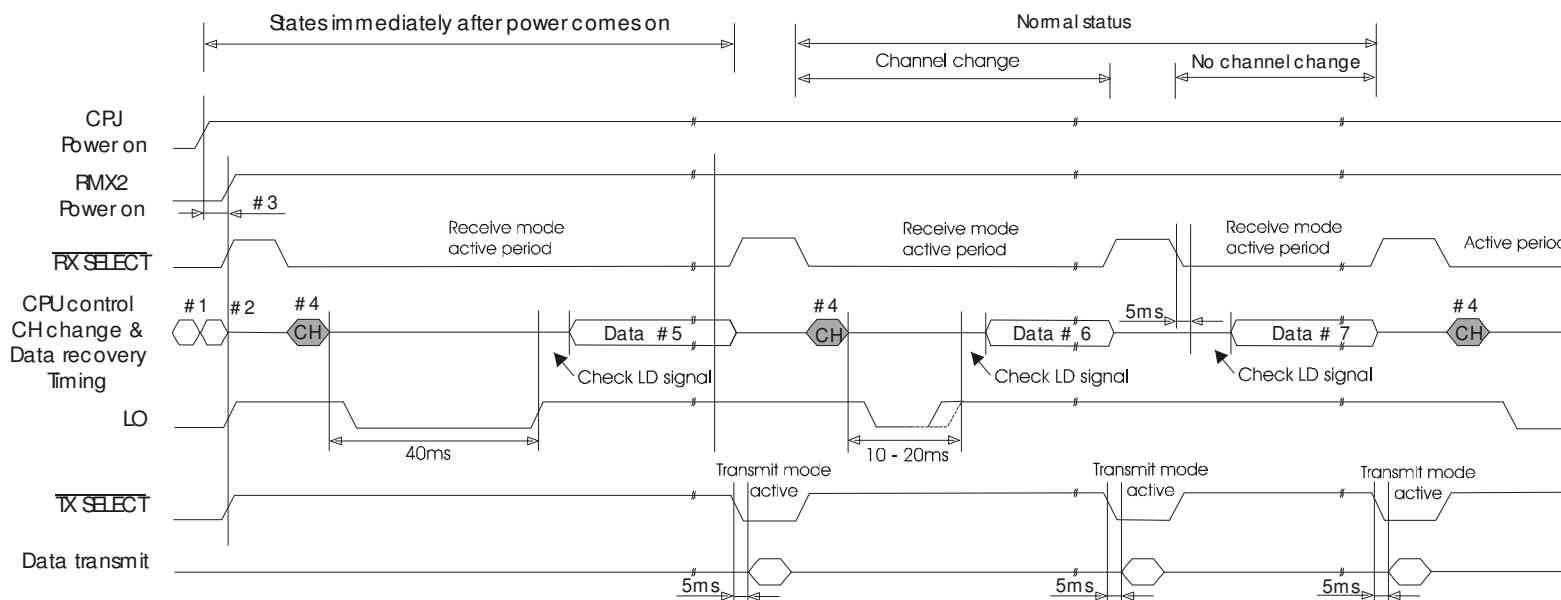

Figure 6: Timing diagram for RMX2

#:1 Reset control CPU

#:2 Initialize the port connected to the module.

#:3 Supply power to the module after initialising CPU.

#:4 Rfchannel change must be performed in receiving mode.

#:5 40 ms later, the receiver can receive the data after changing the channel..

#:6 10 to 20 ms later, the receiver can receive the data after changing the channel.

#:7 5 ms later, the data can be received if the RF channel is not changed.



## PLL frequency setting data reference

**RMX2-433-10:** 433MHz European ISM band (433.050 – 434.790 MHz)

| Parameter name                                | Value    |
|---|----------|
| Phase Comparing Frequency<br>$F_{comp}$ [kHz] | 25       |
| Start Channel Frequency $F_{ch}$<br>[MHz]     | 433.0750 |
| Channel Step Frequency [kHz]                  | 25       |
| Number of Channel                             | 69       |
| Prescaler M                                   | 64       |

|  |                         |
|--|-------------------------|
|  | : For data input        |
|  | : Result of calculation |
|  | : Fixed Vale            |

| Parameter name                      | Value |
|-------------------------------------|-------|
| Reference Frequency $F_{OSC}$ [MHz] | 21.25 |
| Offset Frequency $F_{offset}$ [MHz] | 21.7  |

| Parameter name                       | Value |
|--------------------------------------|-------|
| Reference Counter R                  | 850   |
| Programmable Counter N Min.<br>Value | 257   |
| Programmable Counter N Max.<br>Value | 258   |
| Swallow Counter A Min. Value         | 0     |
| Swallow Counter A Max. Value         | 63    |

| CH. No. | Channel Frequency $F_{ch}$<br>(MHz) | Expect Frequency $F_{expect}$<br>(MHz) | Lock Frequency $F_{VCO}$<br>(MHz) | Number of Division n | Programmable Counter N | Swallow Counter A |
|---------|-------------------------------------|--|-----------------------------------|----------------------|------------------------|-------------------|
| 0       | 433.0750                            | 411.3750                               | 411.3750                          | 16455                | 257                    | 7                 |
| 1       | 433.1000                            | 411.4000                               | 411.4000                          | 16456                | 257                    | 8                 |
| 2       | 433.1250                            | 411.4250                               | 411.4250                          | 16457                | 257                    | 9                 |
| 3       | 433.1500                            | 411.4500                               | 411.4500                          | 16458                | 257                    | 10                |
| 4       | 433.1750                            | 411.4750                               | 411.4750                          | 16459                | 257                    | 11                |
| 5       | 433.2000                            | 411.5000                               | 411.5000                          | 16460                | 257                    | 12                |
| 6       | 433.2250                            | 411.5250                               | 411.5250                          | 16461                | 257                    | 13                |
| 7       | 433.2500                            | 411.5500                               | 411.5500                          | 16462                | 257                    | 14                |
| 8       | 433.2750                            | 411.5750                               | 411.5750                          | 16463                | 257                    | 15                |
| 9       | 433.3000                            | 411.6000                               | 411.6000                          | 16464                | 257                    | 16                |
| 10      | 433.3250                            | 411.6250                               | 411.6250                          | 16465                | 257                    | 17                |
| 11      | 433.3500                            | 411.6500                               | 411.6500                          | 16466                | 257                    | 18                |
| 12      | 433.3750                            | 411.6750                               | 411.6750                          | 16467                | 257                    | 19                |
| 13      | 433.4000                            | 411.7000                               | 411.7000                          | 16468                | 257                    | 20                |
| 14      | 433.4250                            | 411.7250                               | 411.7250                          | 16469                | 257                    | 21                |
| 15      | 433.4500                            | 411.7500                               | 411.7500                          | 16470                | 257                    | 22                |
| 16      | 433.4750                            | 411.7750                               | 411.7750                          | 16471                | 257                    | 23                |
| 17      | 433.5000                            | 411.8000                               | 411.8000                          | 16472                | 257                    | 24                |
| 18      | 433.5250                            | 411.8250                               | 411.8250                          | 16473                | 257                    | 25                |
| 19      | 433.5500                            | 411.8500                               | 411.8500                          | 16474                | 257                    | 26                |
| 20      | 433.5750                            | 411.8750                               | 411.8750                          | 16475                | 257                    | 27                |
| 21      | 433.6000                            | 411.9000                               | 411.9000                          | 16476                | 257                    | 28                |
| 22      | 433.6250                            | 411.9250                               | 411.9250                          | 16477                | 257                    | 29                |
| 23      | 433.6500                            | 411.9500                               | 411.9500                          | 16478                | 257                    | 30                |
| 24      | 433.6750                            | 411.9750                               | 411.9750                          | 16479                | 257                    | 31                |
| 25      | 433.7000                            | 412.0000                               | 412.0000                          | 16480                | 257                    | 32                |
| 26      | 433.7250                            | 412.0250                               | 412.0250                          | 16481                | 257                    | 33                |
| 27      | 433.7500                            | 412.0500                               | 412.0500                          | 16482                | 257                    | 34                |
| 28      | 433.7750                            | 412.0750                               | 412.0750                          | 16483                | 257                    | 35                |
| 29      | 433.8000                            | 412.1000                               | 412.1000                          | 16484                | 257                    | 36                |
| 30      | 433.8250                            | 412.1250                               | 412.1250                          | 16485                | 257                    | 37                |
| 31      | 433.8500                            | 412.1500                               | 412.1500                          | 16486                | 257                    | 38                |
| 32      | 433.8750                            | 412.1750                               | 412.1750                          | 16487                | 257                    | 39                |

|    |          |          |          |       |     |    |
|----|----------|----------|----------|-------|-----|----|
| 33 | 433.9000 | 412.2000 | 412.2000 | 16488 | 257 | 40 |
| 34 | 433.9250 | 412.2250 | 412.2250 | 16489 | 257 | 41 |
| 35 | 433.9500 | 412.2500 | 412.2500 | 16490 | 257 | 42 |
| 6  | 433.9750 | 412.2750 | 412.2750 | 16491 | 257 | 43 |
| 37 | 434.0000 | 412.3000 | 412.3000 | 16492 | 257 | 44 |
| 38 | 434.0250 | 412.3250 | 412.3250 | 16493 | 257 | 45 |
| 39 | 434.0500 | 412.3500 | 412.3500 | 16494 | 257 | 46 |
| 40 | 434.0750 | 412.3750 | 412.3750 | 16495 | 257 | 47 |
| 41 | 434.1000 | 412.4000 | 412.4000 | 16496 | 257 | 48 |
| 42 | 434.1250 | 412.4250 | 412.4250 | 16497 | 257 | 49 |
| 43 | 434.1500 | 412.4500 | 412.4500 | 16498 | 257 | 50 |
| 44 | 434.1750 | 412.4750 | 412.4750 | 16499 | 257 | 51 |
| 45 | 434.2000 | 412.5000 | 412.5000 | 16500 | 257 | 52 |
| 46 | 434.2250 | 412.5250 | 412.5250 | 16501 | 257 | 53 |
| 47 | 434.2500 | 412.5500 | 412.5500 | 16502 | 257 | 54 |
| 48 | 434.2750 | 412.5750 | 412.5750 | 16503 | 257 | 55 |
| 49 | 434.3000 | 412.6000 | 412.6000 | 16504 | 257 | 56 |
| 50 | 434.3250 | 412.6250 | 412.6250 | 16505 | 257 | 57 |
| 51 | 434.3500 | 412.6500 | 412.6500 | 16506 | 257 | 58 |
| 52 | 434.3750 | 412.6750 | 412.6750 | 16507 | 257 | 59 |
| 53 | 434.4000 | 412.7000 | 412.7000 | 16508 | 257 | 60 |
| 54 | 434.4250 | 412.7250 | 412.7250 | 16509 | 257 | 61 |
| 55 | 434.4500 | 412.7500 | 412.7500 | 16510 | 257 | 62 |
| 56 | 434.4750 | 412.7750 | 412.7750 | 16511 | 257 | 63 |
| 57 | 434.5000 | 412.8000 | 412.8000 | 16512 | 258 | 0  |
| 58 | 434.5250 | 412.8250 | 412.8250 | 16513 | 258 | 1  |
| 59 | 434.5500 | 412.8500 | 412.8500 | 16514 | 258 | 2  |
| 60 | 434.5750 | 412.8750 | 412.8750 | 16515 | 258 | 3  |
| 61 | 434.6000 | 412.9000 | 412.9000 | 16516 | 258 | 4  |
| 62 | 434.6250 | 412.9250 | 412.9250 | 16517 | 258 | 5  |
| 63 | 434.6500 | 412.9500 | 412.9500 | 16518 | 258 | 6  |
| 64 | 434.6750 | 412.9750 | 412.9750 | 16519 | 258 | 7  |
| 65 | 434.7000 | 413.0000 | 413.0000 | 16520 | 258 | 8  |
| 66 | 434.7250 | 413.0250 | 413.0250 | 16521 | 258 | 9  |
| 67 | 434.7500 | 413.0500 | 413.0500 | 16522 | 258 | 10 |
| 68 | 434.7750 | 413.0750 | 413.0750 | 16523 | 258 | 11 |

**RMX2-458-10:** 458MHz UK SRD band (458.525 – 459.175 MHz)

| Parameter name                                | Value    |
|---|----------|
| Phase Comparing Frequency<br>$F_{comp}$ [kHz] | 25       |
| Start Channel Frequency $F_{ch}$<br>[MHz]     | 458.5250 |
| Channel Step Frequency [kHz]                  | 25       |
| Number of Channel                             | 27       |
| Prescaler M                                   | 64       |

|  |                         |
|--|-------------------------|
|  | : For data input        |
|  | : Result of calculation |
|  | : Fixed Vale            |

| Parameter name                      | Value |
|-------------------------------------|-------|
| Reference Frequency $F_{OSC}$ [MHz] | 21.25 |
| Offset Frequency $F_{offset}$ [MHz] | 21.7  |

| Parameter name                       | Value |
|--------------------------------------|-------|
| Reference Counter R                  | 850   |
| Programmable Counter N Min.<br>Value | 273   |
| Programmable Counter N Max.<br>Value | 273   |
| Swallow Counter A Min. Value         | 1     |
| Swallow Counter A Max. Value         | 27    |

| CH No. | Channel Frequency $F_{ch}$<br>(MHz) | Expect Frequency $F_{expect}$<br>(MHz) | Lock Frequency $F_{VCO}$<br>(MHz) | Number of Division n | Programmable Counter N | Swallow Counter A |
|--------|-------------------------------------|--|-----------------------------------|----------------------|------------------------|-------------------|
| 0      | 458.5250                            | 436.8250                               | 436.8250                          | 17473                | 273                    | 1                 |
| 1      | 458.5500                            | 436.8500                               | 436.8500                          | 17474                | 273                    | 2                 |
| 2      | 458.5750                            | 436.8750                               | 436.8750                          | 17475                | 273                    | 3                 |
| 3      | 458.6000                            | 436.9000                               | 436.9000                          | 17476                | 273                    | 4                 |
| 4      | 458.6250                            | 436.9250                               | 436.9250                          | 17477                | 273                    | 5                 |
| 5      | 458.6500                            | 436.9500                               | 436.9500                          | 17478                | 273                    | 6                 |
| 6      | 458.6750                            | 436.9750                               | 436.9750                          | 17479                | 273                    | 7                 |
| 7      | 458.7000                            | 437.0000                               | 437.0000                          | 17480                | 273                    | 8                 |
| 8      | 458.7250                            | 437.0250                               | 437.0250                          | 17481                | 273                    | 9                 |
| 9      | 458.7500                            | 437.0500                               | 437.0500                          | 17482                | 273                    | 10                |
| 10     | 458.7750                            | 437.0750                               | 437.0750                          | 17483                | 273                    | 11                |
| 11     | 458.8000                            | 437.1000                               | 437.1000                          | 17484                | 273                    | 12                |
| 12     | 458.8250                            | 437.1250                               | 437.1250                          | 17485                | 273                    | 13                |
| 13     | 458.8500                            | 437.1500                               | 437.1500                          | 17486                | 273                    | 14                |
| 14     | 458.8750                            | 437.1750                               | 437.1750                          | 17487                | 273                    | 15                |
| 15     | 458.9000                            | 437.2000                               | 437.2000                          | 17488                | 273                    | 16                |
| 16     | 458.9250                            | 437.2250                               | 437.2250                          | 17489                | 273                    | 17                |
| 17     | 458.9500                            | 437.2500                               | 437.2500                          | 17490                | 273                    | 18                |
| 18     | 458.9750                            | 437.2750                               | 437.2750                          | 17491                | 273                    | 19                |
| 19     | 459.0000                            | 437.3000                               | 437.3000                          | 17492                | 273                    | 20                |
| 20     | 459.0250                            | 437.3250                               | 437.3250                          | 17493                | 273                    | 21                |
| 21     | 459.0500                            | 437.3500                               | 437.3500                          | 17494                | 273                    | 22                |
| 22     | 459.0750                            | 437.3750                               | 437.3750                          | 17495                | 273                    | 23                |
| 23     | 459.1000                            | 437.4000                               | 437.4000                          | 17496                | 273                    | 24                |
| 24     | 459.1250                            | 437.4250                               | 437.4250                          | 17497                | 273                    | 25                |
| 25     | 459.1500                            | 437.4500                               | 437.4500                          | 17498                | 273                    | 26                |
| 26     | 459.1750                            | 437.4750                               | 437.4750                          | 17499                | 273                    | 27                |

**Note:** In the 458MHz SRD band in the UK, channel frequencies 458.825MHz, 458.8375MHz and 458.900MHz are reserved for alarm usage, and should not be used for general telemetry applications

# **Radiometrix Ltd**

**Hartcran House  
231 Kenton Lane  
Harrow, Middlesex  
HA3 8RP  
ENGLAND**

**Tel: +44 (0) 20 8909 9595  
Fax: +44 (0) 20 8909 2233  
sales@radiometrix.com  
www.radiometrix.com**

## **Copyright notice**

This product data sheet is the original work and copyrighted property of Radiometrix Ltd. Reproduction in whole or in part must give clear acknowledgement to the copyright owner.

## **Limitation of liability**

The information furnished by Radiometrix Ltd is believed to be accurate and reliable. Radiometrix Ltd reserves the right to make changes or improvements in the design, specification or manufacture of its subassembly products without notice. Radiometrix Ltd does not assume any liability arising from the application or use of any product or circuit described herein, nor for any infringements of patents or other rights of third parties which may result from the use of its products. This data sheet neither states nor implies warranty of any kind, including fitness for any particular application. These radio devices may be subject to radio interference and may not function as intended if interference is present. We do NOT recommend their use for life critical applications.

The Intrastat commodity code for all our modules is: 8542 6000

## **R&TTE Directive**

After 7 April 2001 the manufacturer can only place finished product on the market under the provisions of the R&TTE Directive. Equipment within the scope of the R&TTE Directive may demonstrate compliance to the essential requirements specified in Article 3 of the Directive, as appropriate to the particular equipment.

Further details are available on The Office of Communications (Ofcom) web site:

***<http://www.ofcom.org.uk/>***

### *Information Requests*

*Ofcom*

*Riverside House*

*2a Southwark Bridge Road*

*London SE1 9HA*

*Tel: +44 (0)300 123 3333 or 020 7981 3040*

*Fax: +44 (0)20 7981 3333*

*information.requests@ofcom.org.uk*

### *European Communications Office (ECO)*

*Pebblinghus*

*Nansensgade 19*

*DK 1366 Copenhagen*

*Tel. +45 33896300*

*Fax +45 33896330*

*ero@ero.dk*

*www.ero.dk*

---