

BiM2A / BiM2H

Issue 2, 27 July 2012

433MHz Wide Band FM radio transceiver

BiM2A is a half-duplex crystals controlled PLL wideband FM transceiver operating on 433.05-434.79MHz European SRD band.

It is an enhanced replacement for the SAW based BiM2 and has better frequency accuracy and temperature stability.

BiM2H is a high power version with 25mW RF power and specifically made available for Australian/New Zealand users.



Fig. 1: BiM2A-433-64

Features

- Data rates up to 64kbps
- Crystal controlled PLL FM circuitry for both Tx and Rx
- Receiver Sensitivity: -101dBm for 1ppm BER (64kbps)
-104dBm for 1ppm BER (10kbps)
- Supply: 2.9V - 16V @ 14mA TX (10mW), 25mA TX (25mW), 11mA Rx
- Usable range up to 300 metres external, 75 metres in building
- SAW front end filter and full screening
- RSSI (standard) or carrier detect option
- Analogue and digital baseband
- Low profile with small footprint
- 33 x 23 x 5mm
- Conforms to European EN 301 489-3 and ETSI EN 300 220-3 (ERP @ 10mW)
- Conforms to Australian/New Zealand AS/NZS 4268:2003 (ERP @ 25mW)

Instead of the SAW-based technology of the BiM2, the BiM2A and BiM2H use a PLL circuit locked to a crystal for better frequency stability over a wider temperature range (-20C to +70C) and supply range (2.9 – 16V), at the expense of slightly slower power-up. The BiM2A is available as standard on frequencies of 433.92MHz and 434.42MHz.

The BiM2H can be made available if required in an extra-high-power version (BiM2EH), in the same footprint and pinout but giving 100mW nominal output power at 3.7 - 16V supply with a current consumption of less than 60mA.

Applications

- PDAs, organisers and laptops
- Handheld terminals
- EPOS equipment, barcode scanners, belt clip printers
- Data loggers
- Audience response systems
- In-building environmental monitoring and control
- Security and fire alarms
- Restaurant ordering systems
- Vehicle data up/download

Evaluation platforms: UNI-EVAL, NBEK + BiM / SMX carrier

Functional overview

The transmit section of the BiM2A consists of a frequency modulated crystal locked PLL feeding a buffer amplifier and RF filter. A TX select line controls operation. The transmitter achieves full RF output typically within 1ms of this line being pulled low. Modulation is applied at the TXD input and may be either a serial digital stream toggling between 0V and 3V (digital drive) or a high level analogue waveform with the same peak limits (linear drive). Modulation shaping is performed internally by a 2nd order lowpass filter which minimises spectral spreading. The RF output is filtered to ensure compliance with the appropriate regulations and fed via a Tx/Rx changeover switch to the antenna pin.

The receive section is a single conversion FM superhet with an IF of 10.7MHz. A SAW bandpass filter in the receiver front-end provides image rejection and suppression of other unwanted out-of-band signals. Like the transmitter, the receiver is controlled by its own active low RX select line. A post-detection lowpass filter establishes the signal bandwidth and ensures clean operation of the subsequent adaptive data slicer. The slicer is optimised for balanced data such as bi-phase code. The standard module features a received signal strength (RSSI) output with 60dB of range. A version of BiM2A featuring a fast acting Carrier Detect (CD) output on the same RSSI pin is also available. The CD output will indicate the presence of any RF signals on the carrier frequency.

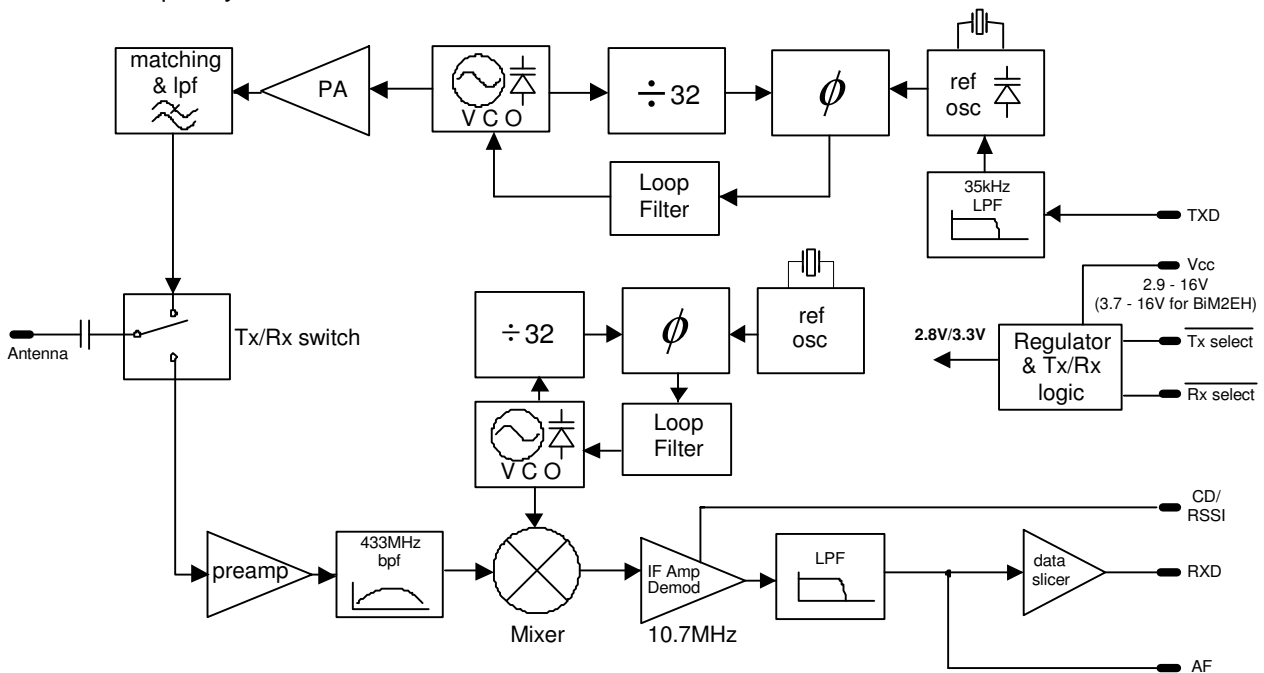

Fig. 2: Block diagram

Pin description

RF GND *pins 1 & 3*

RF ground pins, internally connected to the module screen and to pins 5, 9, 10 & 18 (0V). These pins should be connected directly to the RF return path (e.g. coax braid, main PCB ground plane etc).

Antenna *pin 2*

50Ω RF connection to the antenna, DC-isolated. See pages 7 & 8 for details of suitable antennas and feeds.

0V (GND) *pins 5, 9, 10 & 18*

Supply ground connection and screen.

RSSI *pin 11*

Received Signal Strength Indicator with 60dB range, operational when Rx is enabled. Output voltage nominally 0.17-0.33Vdc (no signal), 1.25Vdc (maximum). See page.8 for typical characteristics.

CD *pin 11*

Carrier Detect - When the receiver is enabled, a low indicates a signal above the detection threshold is being received. The output is high impedance (50kΩ) and should only be used to drive a CMOS logic input.

RXD *pin 12*

Digital output from internal data slicer. The output is a squared version of the signal on pin 13 (AF) and may be used to drive a decoder directly. The data is true data, i.e. as fed to the transmitter. Output is "open-collector" format with internal 10kΩ pullup to Vcc (pin 17).

AF *pin 13*

Buffered & filtered analogue output from FM demodulator. Standing DC bias of 1V approx. Useful for test purposes or for driving external decoders. External load should be >10kΩ // <100pF

TXD *pin 14*

This DC-coupled transmitter modulation input will accept either serial digital data or high level linear signals. Drive signal must be limited to 0V min, 3V max (0 - 5V for BIM2EH). See page 5 for suggested drive methods. Input impedance >50kΩ.

TX select *pin 15*

Active-low Transmit select. 47kΩ internal pull-up to Vcc.

RX select *pin 16*

Active-low Receive select. 47kΩ internal pull-up to Vcc.

| Pin 15 TX | Pin 16 RX | Function |
|-----------|-----------|----------------------|
| 1 | 1 | Power down (<10μA) |
| 1 | 0 | Receiver enabled |
| 0 | 1 | Transmitter enabled |
| 0 | 0 | Self test loop-back* |

* Loop-back allows the receiver to monitor the transmitted signal. Under these conditions the Tx radiated signal level will be reduced to approximately -10dBm).

Vcc *pin 17*

DC +ve supply pin. +2.9 to +16 volts @ <14mA (@10mW). The supply should be clean, <20mV_{P-P} ripple.

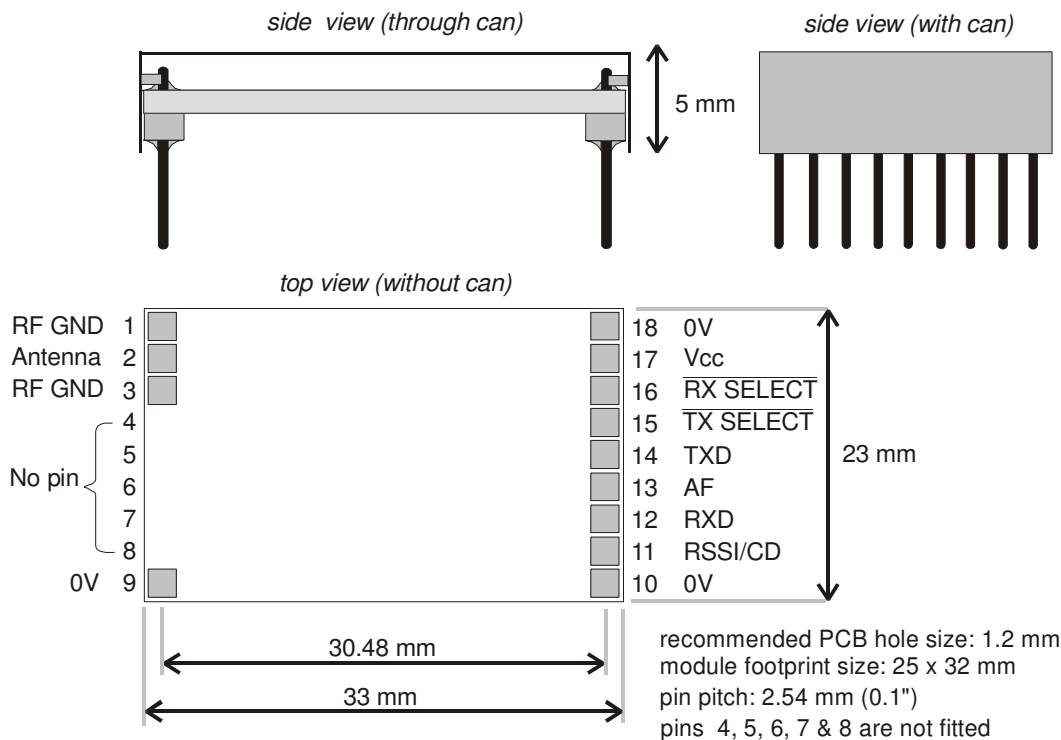

Fig. 3: Physical dimensions

Weight: 7g (typ.)

Absolute maximum ratings

Exceeding the values below may cause permanent damage to the module.

| | |
|-----------------------------|--------------------|
| Operating temperature | -20°C to +70°C |
| Storage temperature | -40°C to +100°C |
| Vcc (pin 17) | -0.3V to +16V |
| TX, RX select (pins 15, 16) | -9V to +16V |
| All other pins | -0.3V to +Vcc |
| Antenna (pin 2) | ±50V DC, +10dBm RF |

Performance specifications

Figures apply to standard version @ Vcc=3.0V, temperature +20°C, unless stated.

| General | pin | min. | typ. | max. | units | notes |
|--|--------|---------|--------|------|-------|-----------------|
| Supply voltage | 17 | 2.9 | 3.0 | 16.0 | V | |
| Supply voltage (BiM2EH) | 17 | 3.7 | 5.0 | 16.0 | V | |
| Tx supply current @ 10mW | 17 | - | 14 | - | mA | |
| Tx supply current @ 25mW | 17 | - | 25 | - | mA | |
| Tx supply current @ 100mW | 17 | - | 60 | - | mA | |
| Rx supply current | 17 | 10 | 11 | 17 | mA | Note 1 |
| RF centre frequency | - | - | 433.92 | - | MHz | - |
| Antenna port impedance | 2 | - | 50 | - | Ω | Tx or Rx |
| TX & RX select: high (<i>deselect</i>) | 15, 16 | Vcc-0.5 | | Vcc | V | |
| low (<i>select</i>) | 15, 16 | 0 | | 0.5 | V | |
| Internal select pull-ups | 15,16 | - | 47 | - | kΩ | To Vcc (pin 17) |
| Balanced code bit rate | 12 | - | - | 64 | kbps | -64 version |
| Balanced code bit rate | 12 | - | - | 10 | kbps | -10 version |

| Transmitter section | pin | min. | typ. | max. | units | notes |
|-----------------------------------|-------|------|------|------|-------|------------|
| RF power output (BiM2A) | 2 | +9 | +10 | +11 | dBm | |
| RF power output (BiM2H) | 2 | +13 | +14 | +15 | dBm | |
| RF power output (BiM2EH) | 3 | +19 | +20 | +21 | dBm | |
| TX harmonics/spurious emission | 2 | - | -55 | -40 | dBm | |
| Initial centre frequency accuracy | - | -10 | 0 | +10 | kHz | |
| FM deviation | - | ±20 | ±27 | ±35 | kHz | Peak |
| Modulation bandwidth | - | 0 | - | 35 | kHz | @ -3db |
| Modulation distortion | - | - | 5 | 10 | % | Note 2 |
| TX spectral bandwidth @-40dBc | 2 | - | - | 250 | kHz | worst case |
| TXD input level: high | 14 | 2.8 | - | 3.0 | V | Note 3 |
| high (BiM2EH) | 14 | - | 5.0 | - | V | Note 3 |
| low | 14 | 0 | - | 0.2 | V | Note 3 |
| TX power up to full RF | 2, 15 | - | 1 | 1.5 | ms | Note 4 |

| Receiver section | pin | min. | typ. | max. | units | notes |
|--|-------|------|------|------|--------|-----------------|
| RF sensitivity, 10dB S/N | 2, 13 | - | -106 | - | dBm | -64 version |
| RF sensitivity, 1ppm BER | 2, 12 | - | -100 | - | dBm | -64 version |
| RF sensitivity, 10dB S/N | 2, 13 | - | -113 | - | dBm | -10 version |
| RF sensitivity, 1ppm BER | 2, 12 | - | -107 | - | dBm | -10 version |
| RSSI output, no signal | 11 | 0.15 | 0.25 | 0.4 | V | |
| RSSI output, max indication | 11 | 1 | 1.12 | 1.25 | V | -50dBm RF input |
| RSSI range | 2, 11 | - | 60 | - | dB | |
| IF bandwidth | - | - | 180 | - | kHz | |
| Image rejection (f _{RF} =21.4MHz) | 2 | 40 | 50 | - | dB | |
| IF rejection (10.7MHz) | 2 | 100 | - | - | dB | |
| Local osc. leakage, conducted | 2 | - | -117 | -110 | dBm | |
| Baseband bandwidth @ -3dB | 13 | 0 | - | 50 | kHz | -64 version |
| Baseband bandwidth @ -3dB | 13 | 0 | - | 7.8 | kHz | -10 version |
| AF output signal level | 13 | 200 | 300 | 400 | mV p-p | Note 5 |
| DC offset on AF output | 13 | 0.3 | 1.0 | 1.75 | V | Note 6 |

| Receiver section | pin | min. | typ. | max. | units | notes |
|---|--------|------|------|------|-------|-----------------|
| Distortion on recovered AF | 13 | - | 1 | 10 | % | Note 7 |
| Ultimate (S+N)/N | 13 | - | 40 | - | dB | -50dBm RF input |
| Load capacitance, AF & RXD | 12, 13 | - | - | 100 | pF | |
| Dynamic Timing | | | | | | |
| <i>Rx power up with signal present</i> | | | | | | |
| Power up to valid RSSI, $t_{PU-RSSI}$ | 11 | - | 1 | - | ms | |
| Power up to valid CD, t_{PU-CD} | 11 | - | 1.5 | - | ms | |
| Power up to stable data, $t_{PU-data}$ | 12 | - | 5 | 10 | ms | -64 version |
| Power up to stable data, $t_{PU-data}$ | 12 | - | 10 | 30 | ms | -10 version |
| <i>Signal applied with Rx on</i> | | | | | | |
| RSSI response time (rise/fall) | 11 | - | 100 | - | □s | |
| Signal to stable data, $t_{sig-data}$ | 12 | - | 5 | 10 | ms | -64 version |
| Signal to stable data, $t_{sig-data}$ | 12 | - | 5 | 30 | ms | -10 version |
| Allowable time between data transitions | 14 | 15.6 | - | 1500 | μs | -64 version |
| Allowable time between data transitions | 14 | 0.1 | - | 15 | ms | -10 version |
| Averaged code mark:space | 14 | 20 | 50 | 80 | % | Note 8 |

- Note:**
1. Increases at high RF input level (>-20dBm)
 2. See page 6 for further details
 3. For specified FM deviation
 4. Tx select low > full RF output
 5. ±30kHz FM deviation
 6. Min/max at ±50kHz offset
 7. Max at ±50kHz offset
 8. Average, at max. data rate

Application Information

Modulation formats and range extension

The BiM2A/H module will produce the specified FM deviation with a 2-level digital input to TXD which toggles between 0V and 3V. Reducing the amplitude of the data input (to the TXD pin) from this value reduces the transmitted FM deviation, typically to ± 20 -22kHz minimum at 2.7V. The receiver will cope with this quite happily and no significant degradation of link performance should be observed.

TXD is normally driven directly by logic levels but will also accept analogue drive, e.g. 2-tone signalling. In this case it is recommended that TXD (pin 14) should be DC-biased to 1.5V with the modulation AC-coupled and limited to a maximum of 3V peak-to-peak. The instantaneous modulation voltage must not swing below 0V or above 3V at any time if waveform distortion and excessive FM deviation is to be avoided – use a resistive potential divider and/or level shifter to accomplish this if necessary. The varactor modulator in the transmitter introduces some 2nd harmonic distortion which may be reduced if necessary by predistortion of the analogue waveform.

At the other end of the link the AF output (pin 13) can be used to drive an external decoder directly.

Although the module baseband response extends down to DC, data formats containing a DC component are unsuitable and should not be used. This is because frequency errors and drifts between the transmitter and receiver occur in normal operation resulting in DC offset errors on the AF output.

The time constant of the adaptive data slicer in the BiM2A is set at a reasonable compromise to allow the use of low code speeds where necessary whilst keeping settling times acceptably fast for battery-economised operation. RXD output on pin 12 is “true” sense, i.e. as originally fed to the transmitter.

In applications such as longer range fixed links where data speed is not of primary importance, a significant increase in range can be obtained by using the slowest possible data rate together with filtering to reduce the receiver bandwidth to the minimum necessary. In these circumstances the AF output can be used to drive an external filter and data slicer. The AF output waveform on pin 13 is in the same sense as that originally fed to the transmitter, i.e. no inversion takes place.

Expected range

Predicting the range obtainable in any given situation is notoriously difficult since there are many factors involved. The main ones to consider are as follows:

- Type and location of antennas in use (see below)
- Type of terrain and degree of obstruction of the link path
- Sources of interference affecting the receiver
- “Dead” spots caused by signal reflections from nearby conductive objects
- Data rate and degree of filtering employed

Assuming the maximum 64kb/s data rate and $\frac{1}{4}$ -wave whip antennas on both transmitter (@10mW) and receiver, the following ranges may be used as a rough guide only:

| | | |
|--|---|----------|
| Cluttered/obstructed environment, e.g. inside a building | : | 50-75m |
| Open, relatively unobstructed environment | | 200-300m |

It must be stressed, however, that range could be much greater or much less than these figures. Range tests should *always* be performed before assuming that a particular range can be achieved in any given application.

Antenna considerations and options

The choice and positioning of transmitter and receiver antennas is of the utmost importance and is the single most significant factor in determining system range. The following notes are intended to assist the user in choosing the most effective arrangement for a given application.

Nearby conducting objects such as a PCB or battery can cause detuning or screening of the antenna which severely reduces efficiency. Ideally the antenna should stick out from the top of the product and be entirely in the clear, however this is often not desirable for practical or ergonomic reasons and a compromise may need to be reached. If an internal antenna must be used, try to keep it away from other metal components and pay particular attention to the “hot” end (i.e. the far end), as this is generally the most susceptible to detuning. The space around the antenna is as important as the antenna itself.

Microprocessors and microcontrollers tend to radiate significant amounts of radio frequency hash, which can cause desensitisation of the receiver if its antenna is in close proximity. 433MHz is generally less prone to

this effect than lower frequencies, but problems can still arise. Things become worse as logic speeds increase, because fast logic edges are capable of generating harmonics across the UHF range which are then radiated effectively by the PCB tracking. In extreme cases system range can be reduced by a factor of 3 or more. To minimise any adverse effects, situate the antenna and module as far as possible from any such circuitry and keep PCB track lengths to the minimum possible. A ground plane can be highly effective in cutting radiated interference and its use is strongly recommended.

A simple test for interference is to monitor the receiver RSSI output voltage, which should be the same regardless of whether the microcontroller or other logic circuitry is running or in reset.

Two types of antenna are recommended for use with the BiM2A:

Whip ($\frac{1}{4}$ wave). This consists simply of a piece of wire or rod connected to the module at one end. The lengths given below are from module pin to antenna tip including any interconnecting wire or tracking (but **not** including any 50 Ω coax or microstrip connection). This antenna is simple, cheap, easy to set up and performs well. It is especially effective when used with a ground plane, which in practice is often provided by the main PCB or by a metal case.

Base-loaded whip. In applications where space is at a premium a shortened whip may be used, tuned by means of a coil inserted at the base. This coil may be air-wound for maximum efficiency, or a small SMT inductor can be used. The value must be empirically chosen to tune the particular length of whip for best results "in situ", making this antenna more difficult to set up. Radiated power will generally be slightly less than that obtained from a $\frac{1}{4}$ -wave whip.

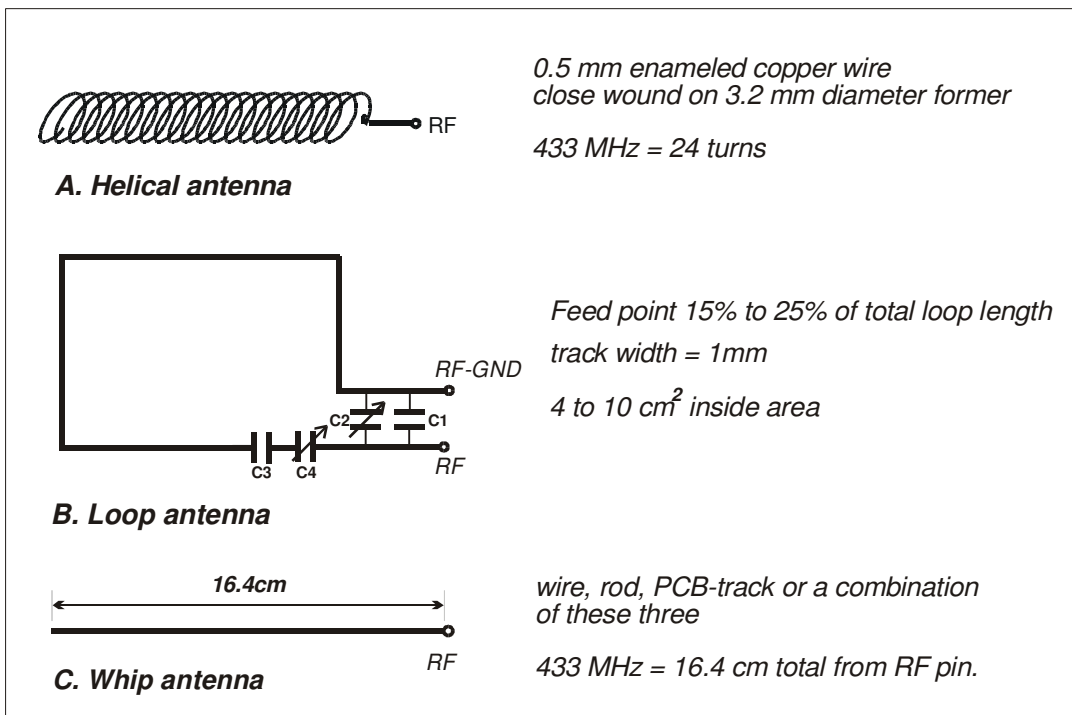

Fig. 4: Antenna configurations

Note: Where the specified antennas are mounted on the PCB and/or in close proximity to metalwork (module casing, components, PCB tracking etc), the antenna radiation pattern may be seriously affected. Radiated power may be significantly increased in some directions (sometimes by as much as 10dB) and correspondingly reduced in others. This may adversely affect system performance where good all-round coverage is desired.

Care should also be taken to ensure that this effect does not increase the radiated power in any direction beyond that allowed by type approval regulations. Where this occurs the antenna may need to be relocated. In extreme cases a resistive attenuator of appropriate value may be required between the module and antenna.

Received Signal Strength Indicator (RSSI)

The BiM2A receiver incorporates a wide range RSSI which measures the strength of an incoming signal over a range of approximately 60dB. This allows assessment of link quality and available margin and is useful when performing range tests.

Please note that the actual RSSI voltage at any given RF input level varies somewhat between units. The RSSI facility is intended as a relative indicator only - it is not designed to be, or suitable as, an accurate and repeatable measure of absolute signal level or transmitter-receiver distance.

The output on pin 11 of the module has a standing DC bias in the region of 0.25V with no signal, rising to around 1.12V at maximum indication (RF input levels of -50dBm and above). For any given RF input level, absolute RSSI voltage is likely to vary somewhat between individual units - please refer to specifications table on p4.

The RSSI output source impedance is high ($\sim 50k\Omega$) and external loading should therefore be kept to a minimum.

Typical RSSI characteristic is shown below (this is for indicative purposes only and is not a guarantee of actual RSSI characteristics):

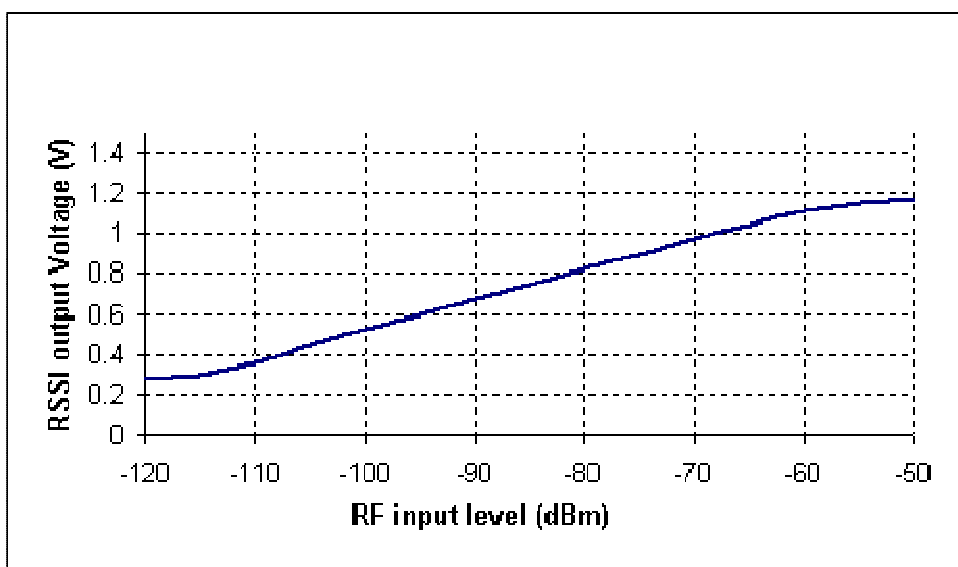

Fig.5: Typical RSSI response curve

To ensure a reasonably fast response the RSSI has limited internal decoupling of 1nF to ground. This may result in a small amount of audio ripple on the DC output at pin 11 of the module. If this is a problem further decoupling may be added at the expense of response speed, in the form of a capacitor from pin 11 to ground. For example, adding 10nF here will increase RSSI response time from 100 μ s to around 1ms. The value of this capacitor may be increased without limit.

Type Approval requirements: Europe

The modules comply with the requirements of the R&TTE Directive (including standards EN 300 220-3 and EN 301 489-3) when used in accordance with the information contained herein. The following provisos apply:

- 1) The modules must not be modified or used outside their specification limits.
- 2) The modules may only be used to transfer digital or digitised data. Analogue speech and/or music are not permitted.
- 3) The equipment in which the BiM2A is used must carry all necessary external labelling to meet the requirements of the R&TTE directive.
- 4) The BiM2A has not been tested with antennas having gains greater than that of a quarter-wave whip. The use of such antennas may require further R&TTE approval.

Module mounting considerations

Good RF layout practice should be observed. In particular, any ground return required by the antenna or feed should be connected directly to the RF GND pins at the antenna end of the module, and not to the OV pins which are intended as DC grounds only. All connecting tracks should be kept as short as possible to avoid any problems with stray RF pickup.

If the connection between module and antenna does not form part of the antenna itself, it should be made using 50Ω microstrip line or coax or a combination of both. It is desirable (but not essential) to fill all unused PCB area around the module with ground plane.

Variants and ordering information

The BiM2A/BiM2H receivers are manufactured in several variants:

| | | | |
|-------------------|-----------------|--------------------------------------|------------------------|
| Data rate: | Slower version: | 7.8kHz baseband B/W, (suffix -10) | data rate up to 10kb/s |
| | Faster version: | 50kHz baseband B/W, (suffix -64) | data rate up to 64kb/s |
| Frequency: | 433.92MHz | (suffix -433) | |
| | 434.42MHz | (suffix -434) | |

For European applications in the 433.05 – 433.79870MHz band:
Standard Frequency = 433.92MHz

| Part number | RF power | Data rate | TXD input level |
|----------------------|----------|-----------|-----------------|
| CD versions | | | |
| BiM2A-433-64-CD-3V | +10dBm | 64kbps | 0 - 3V |
| BiM2A-433-10-CD-3V | +10dBm | 10kbps | 0 - 3V |
| BiM2A-433-64-CD-5V | +10dBm | 64kbps | 0 - 5V |
| BiM2A-433-10-CD-5V | +10dBm | 10kbps | 0 - 5V |
| RSSI versions | | | |
| BiM2A-433-64 | +10dBm | 64kbps | 0 - 3V |
| BiM2A-433-10 | +10dBm | 10kbps | 0 - 3V |
| BiM2H-433-64 | +14dBm | 64kbps | 0 - 3V |
| BiM2H-433-10 | +14dBm | 10kbps | 0 - 3V |
| BiM2EH-433-64 | +20dBm | 64kbps | 0 - 5V |
| BiM2EH-433-10 | +20dBm | 10kbps | 0 - 5V |

Note: Non-standard frequency variants can be supplied to individual customer requirements. Minimum order quantities apply. Please consult the Sales department for further information.

Radiometrix Ltd

Hartcran House
231 Kenton Lane
Harrow, Middlesex
HA3 8RP
ENGLAND

Tel: +44 (0) 20 8909 9595

Fax: +44 (0) 20 8909 2233

sales@radiometrix.com

www.radiometrix.com

Copyright notice

This product data sheet is the original work and copyrighted property of Radiometrix Ltd. Reproduction in whole or in part must give clear acknowledgement to the copyright owner.

Limitation of liability

The information furnished by Radiometrix Ltd is believed to be accurate and reliable. Radiometrix Ltd reserves the right to make changes or improvements in the design, specification or manufacture of its subassembly products without notice. Radiometrix Ltd does not assume any liability arising from the application or use of any product or circuit described herein, nor for any infringements of patents or other rights of third parties which may result from the use of its products. This data sheet neither states nor implies warranty of any kind, including fitness for any particular application. These radio devices may be subject to radio interference and may not function as intended if interference is present. We do NOT recommend their use for life critical applications.

The Intrastat commodity code for all our modules is: 8542 6000

R&TTE Directive

After 7 April 2001 the manufacturer can only place finished product on the market under the provisions of the R&TTE Directive. Equipment within the scope of the R&TTE Directive may demonstrate compliance to the essential requirements specified in Article 3 of the Directive, as appropriate to the particular equipment.

Further details are available on The Office of Communications (Ofcom) web site:

<http://www.ofcom.org.uk/>

Information Requests
Ofcom
Riverside House
2a Southwark Bridge Road
London SE1 9HA
Tel: +44 (0)300 123 3333 or 020 7981 3040
Fax: +44 (0)20 7981 3333
information.requests@ofcom.org.uk

European Communications Office (ECO)
Peblingehus
Nansensgade 19
DK 1366 Copenhagen
Tel. +45 33896300
Fax +45 33896330
ero@ero.dk
www.ero.dk