

400mW Multichannel 869MHz band transceiver

FPX3 is a small, high power (half-watt) multi-channel wide band FM transceiver, operating in the Europe-wide 869.40 - 869.65MHz sub-band. It is also available in the Indian licence free 865-867MHz band (General telemetry and RFID).



Figure 1: FPX3-869-20

Features

- Conforms to ETSI EN 300 220-3 and EN 301 489-3
- Conforms to Indian low power requirements for 865 - 867 MHz band
- High performance PLL synthesizer
- +26dBm RF power output
- Data rates up to 20 kbps for standard module
- Usable range over 3km
- Fully screened. Low profile
- Feature-rich interface (RSSI, analogue and digital baseband)
- Re-programmable via RS232 interface

Applications

- Asset tracking systems
- Industrial telemetry and telecommand
- High performance security system
- Fire alarms
- ROV control applications
- High speed data modems

Technical Summary

- Operating frequency: 868 – 870MHz (EU), 865 - 867MHz (India)
- Maximum of 8 channels (depends on band allocation and data rate)
- Transmit power: 400mW (+26dBm) nominal
- Supply range: +5V regulated
- Current consumption: 500mA (at 400mW output) transmit, 50mA receive
- Data bit rate: 20kbps max. (standard module)
- Receiver sensitivity: -115dBm for 12dB SINAD (20kbps variant)
-117dBm for 12dB SINAD (10kbps variant)
- Size: 67 x 30 x 12mm

Evaluation Platform: Narrow Band Evaluation Kit

FPX3 869MHz half-watt wideband multichannel transceiver

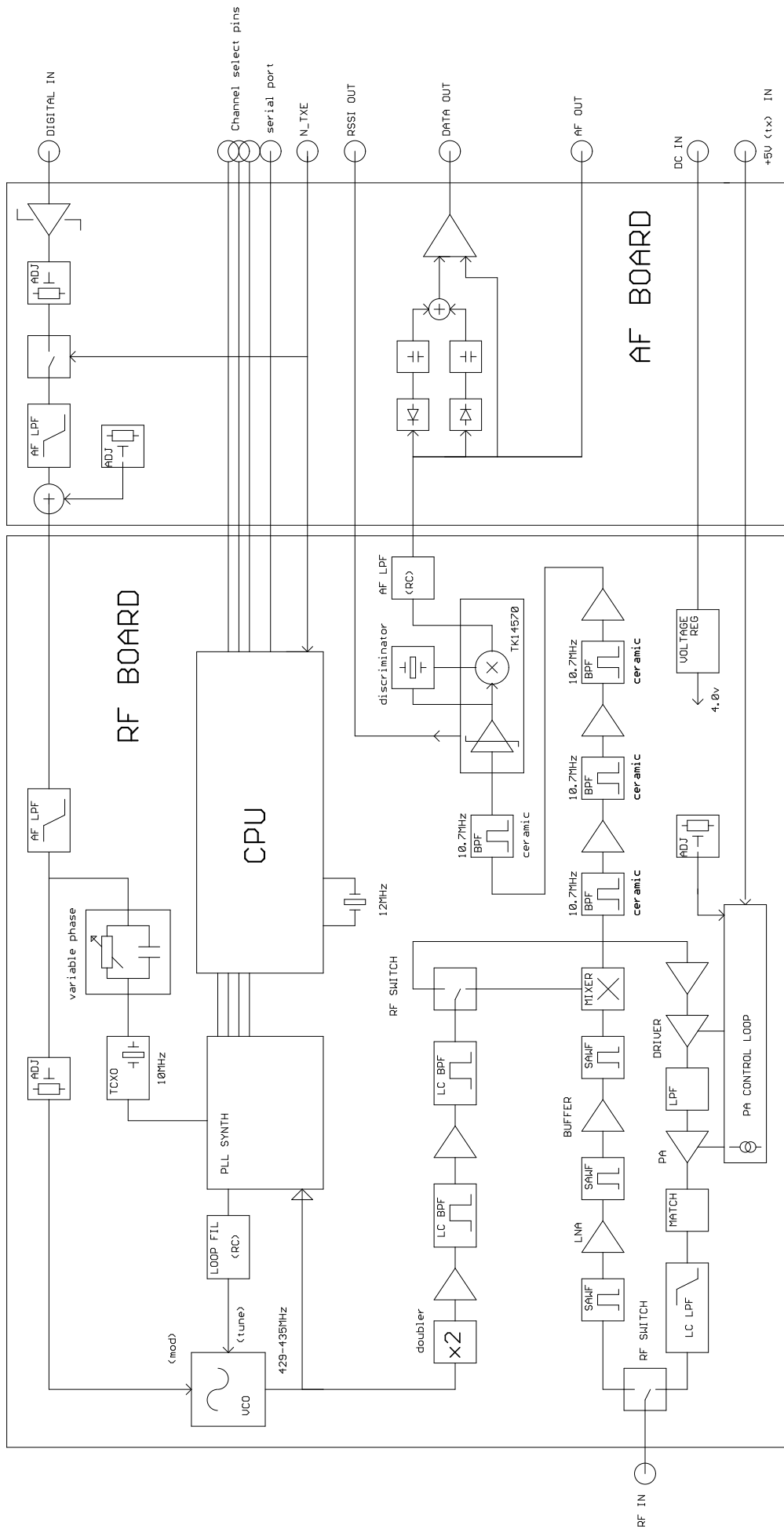

Figure 2: FPX3 block diagram

FPX3 FOOTPRINT

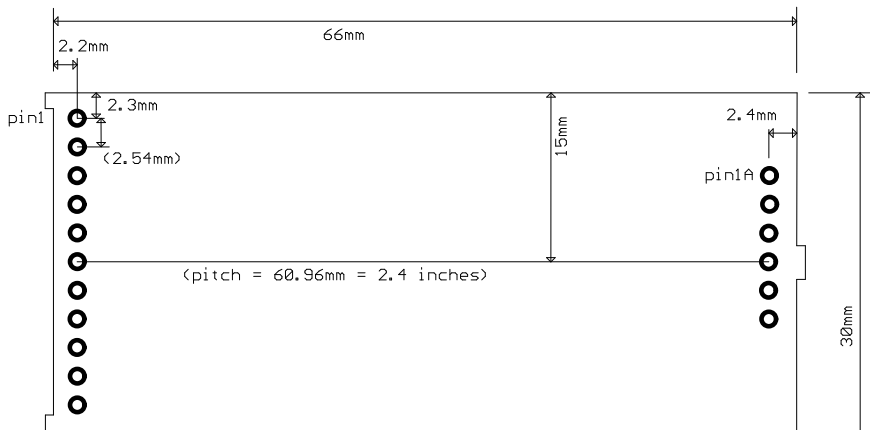

Figure 3: FPX3 footprint (Top) view

Pin Description

Pins		Normal mode
RF		
1A	NO PIN	
2A	RF in/out	To the antenna
3A	RF Gnd	RF ground
4A	GND	0V
5A	GND	0V
6A	Vcc (TX)	+5V regulated supply for TX ⁷
User		
1	TXD	DC coupled input for 5v pp CMOS logic waveforms
2	TXE	Transmit enable. Low = TX mode
3	GND	0V
4	Vcc	DC supply input (+5V regulated) ⁸
5	P3	Parallel channel select
6	P2	Parallel channel select
7	P1	Parallel channel select
8	PGM in	Serial programming/control input (inverted logic level RS232)
9	RSSI	DC level between 0.5V and 2.5V. 60dB dynamic range
10	RXD	Open collector output of data slicer. 47K pullup to 4V
11	AF out	500mV p-p audio. DC coupled, approx 0.8V bias

NOTES:

- No inversion occurs between TXD and RXD.
- P1 - P3 (parallel channel selects) and N_TXE are active LOW and have internal 47K pullups to 4v
- RXD is an open collector output, with a weak pullup to 4v (approx 50K)
- This radio has no 'internal modem' functions in this version.
- Programming port (P0) operates at 2400 baud. (Command set specific to this design). The unit is capable of operating in 'basic' parallel channel select only mode, or in serial controlled 'expanded' mode
- The high current (500mA maximum) transmitter supply (5v regulated) is fed to a separate pin, on the RF out connector.
The V supply (pin 4 on the user connector) also requires a 5v regulated supply, and draws up to 50mA
Both pins must be supplied at all times (most users connect them to a common +5v supply)
- 10% duty cycle: While the FPX3 is capable of transmitting continuously (the case temperature will rise noticeably) this will be in contravention of the sub-band restrictions.
Units operating in the high power 869.4-869.65MHz sub-band are limited to 10% maximum transmit duty cycle. It is the responsibility of the user to ensure that this restriction is complied with.
Alternatively, the user may wish to implement a listen-before-talk protocol (using the RSSI output).
See EN300-220 for further details

Serial interface commands

Serial data is sent to the unit on the programming input (PGM).
To successfully program the unit, it must be powered

Unlike earlier Radiometrix multichannel units, the FPX3 has separate N and R registers for each channel, on transmit and on receive. In other words, the frequency of each channel is individually programmed in every mode.

Commands include:

Commands	Function
GOCHAN a	serial select of channel a (ch0 to 7)
SETPAR	channel selected by 3 bit parallel input
SETSER	channel selected by most recent 'gochan' operation
<cr>	process entry
/	clear all buffers
#	disable command mode

Most users will not need to edit the table which relates channel frequency, channel number and synthesizer register programming values. The commands below are used to access the eeprom table containing this information.

Users should be warned that, in order to get the optimum switching speed from the module, the standard channel setup uses a different reference frequency for each channel, and the absolute calculated channel frequency is allowed to deviate by up to +/-2KHz from the nominal

LOADaa nnnnn (aa = 0 – 7)	load the N values for receive operation
LOADaa rrrrr (aa = 8 – 15)	load the R values for receive operation
LOADaa nnnnn (aa = 16 – 23)	load the N values for transmit operation
LOADaa rrrrr (aa = 24 – 31)	load the R values for transmit operation

Reference frequency (10MHz/R) must be in the range 210 to 300KHz (tx) or 175 to 300KHz (rx).
As a rule of thumb, an R value greater than 45 (tx) or 55 (rx) should be viewed with suspicion.

a = single digit channel number from 0 to 7

aa = eeprom location number from 0 to 31

nnnnn = a synthesizer N register value, (up to 65535)

rrrrr = the synthesizer R register value, (up to 16383)

ALL COMMANDS MUST BE IN UPPER CASE.

Notice that the synthesizer and VCO operate at half the output frequency, so for a frequency of 869.475MHz, the actual N/R values will be set for 434.7375MHz

Further information TBA

NOTE:

- A pause of at least 50ms must be allowed between command strings (EEPROM programming time)

Condensed specifications

Frequency	868 – 870MHz (EU) 865 - 867MHz (<i>India</i>)	
<i>Frequency stability</i>	+/-5ppm (better than ±5kHz)	
<i>Channel spacing</i>	100kHz (FPX3-86x-20) 50kHz (FPX3-86x-10)	
<i>Number of channels</i>	8 maximum FPX3-869-20 for EU CH0: 869.475MHz, CH1-CH3: 869.565MHz CH4-CH7=869.50MHz for backward compatibility	
	FPX3-869-10 for EU CH0:869.450MHz, CH1:869.500MHz, CH2:869.550MHz, CH3:869.600MHz, CH4-CH7=869.50MHz for backward compatibility	
	FPX3-866-10 or FPX3-866-20 for India CH0 = 865.143 MHz CH1 = 865.294 MHz CH2 = 865.500 MHz CH3 = 865.789 MHz CH4 = 866.047 MHz CH5 = 866.383 MHz CH6 = 866.531 MHz CH7 = 866.829 MHz	
Supply	Receive	5.0V regulated at 50mA
	Transmit:	5.0V regulated at 500mA for 400mW output
Operating temperature	-20 to +70 °C (Storage -30 to +70 °C)	
Spurious radiations	Compliant with ETSI EN 300 220-2 and EN 301 489-3 (EU)	
Interface		
	<i>User</i>	11 pin 0.1" pitch molex
	<i>RF and TX supply</i>	5 pin 0.1" pitch molex
Recommended PCB hole size	1.2mm (min.)	
Size	67 x 30 x 12mm	
Transmitter		
Output power	400mW (+26dBm)	
TX on switching time	5 ms	
Modulation type	FM, FSK (F1D, F3D)	
TX modulation bandwidth	DC – 10kHz	
Peak FM Deviation	±16kHz nominal (FPX3-xxx-20) ±8kHz nominal (FPX3-xxx-10)	
Adjacent channel TX power	-37dBm	
TX spuri	<-36dBm	
Inputs	5V pk-pk CMOS data	
Receiver		
Sensitivity	-117dBm for 12dB SINAD at 1KHz (FPX3-xxx-10) -115dBm for 12dB SINAD at 1KHz (FPX3-xxx-20) -107dBm for <0.1% data errors (20kbps NRZ)	
image / spurious	-55dB	
blocking	-80dB	
adjacent channel	-60dB (Tested per. ETSI 300-220-2)	
Outputs	RSSI, Audio, Data	

Ordering Information

Part No.	Description	Frequency band (MHz)
FPX3-869-10	10kbps, 4-channel EU version	869.40 – 869.65 MHz
FPX3-869-20	20kbps, 2-cannnel EU version	869.40 – 869.65 MHz
FPX3-866-10-IND	10kbps, 8-channel Indian version	865 – 867 MHz
FPX3-866-20-IND	20kbps, 8-channel Indian version	865 – 867 MHz

CEPT/ERC Rec 70-03, 868 MHz Band Plan

Applications	Non-specific SRD	Alarm	Non-specific SRD	Social Alarm	Alarm	Non-specific SRD	Alarm	Non-specific SRD
Channel Spacing	No Spacing	25kHz or WB	No Spacing	25kHz	25kHz	25kHz or Wide Band	25kHz	No Spacing
Duty Cycle	<1% or LBT	<1%	<0.1% or LBT	<0.1%	<0.1%	<1% or LBT	<10%	up to 100%

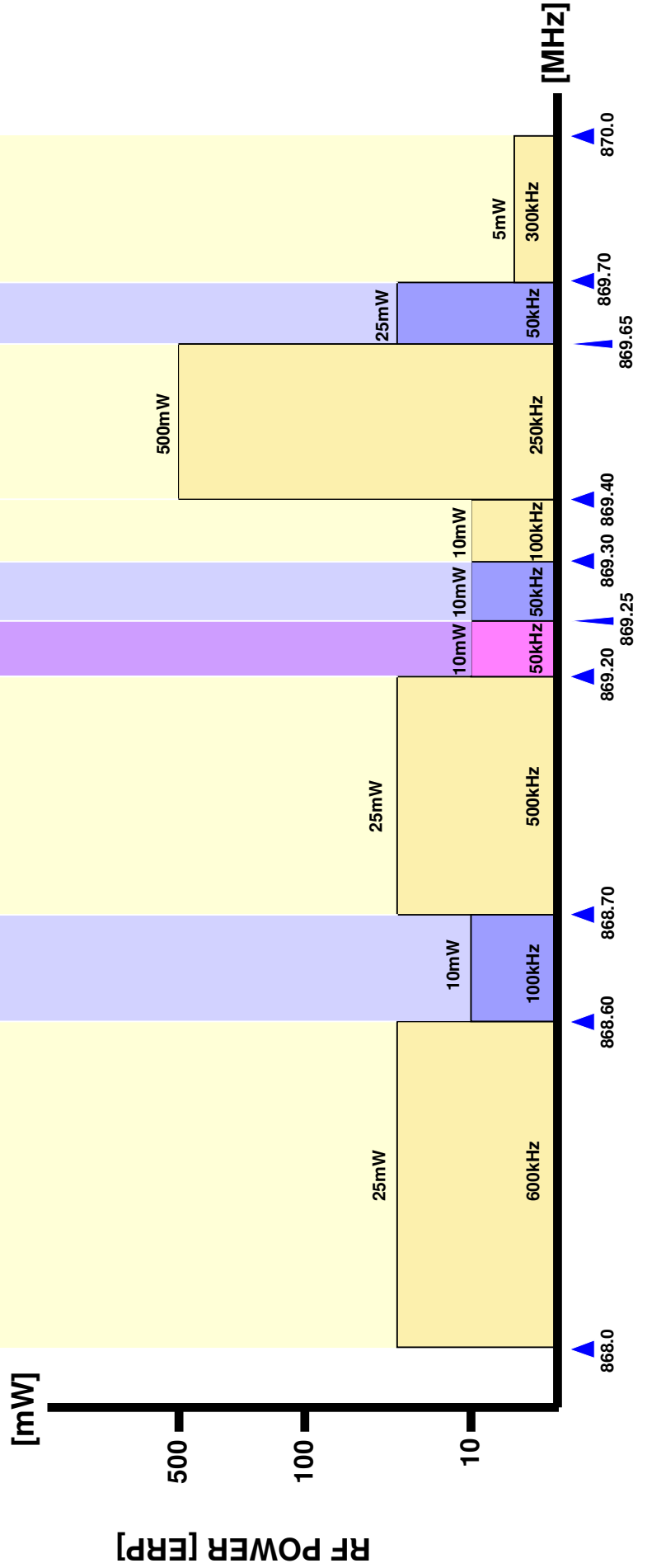

Radiometrix Ltd

**Hartcran House
231 Kenton Lane
Harrow, Middlesex
HA3 8RP
ENGLAND**

Tel: +44 (0) 20 8909 9595

Fax: +44 (0) 20 8909 2233

sales@radiometrix.com

www.radiometrix.com

Copyright notice

This product data sheet is the original work and copyrighted property of Radiometrix Ltd. Reproduction in whole or in part must give clear acknowledgement to the copyright owner.

Limitation of liability

The information furnished by Radiometrix Ltd is believed to be accurate and reliable. Radiometrix Ltd reserves the right to make changes or improvements in the design, specification or manufacture of its subassembly products without notice. Radiometrix Ltd does not assume any liability arising from the application or use of any product or circuit described herein, nor for any infringements of patents or other rights of third parties which may result from the use of its products. This data sheet neither states nor implies warranty of any kind, including fitness for any particular application. These radio devices may be subject to radio interference and may not function as intended if interference is present. We do NOT recommend their use for life critical applications.

The Intrastat commodity code for all our modules is: 8542 6000

R&TTE Directive

After 7 April 2001 the manufacturer can only place finished product on the market under the provisions of the R&TTE Directive. Equipment within the scope of the R&TTE Directive may demonstrate compliance to the essential requirements specified in Article 3 of the Directive, as appropriate to the particular equipment.

Further details are available on The Office of Communications (Ofcom) web site:

<http://www.ofcom.org.uk/>

Information Requests

Ofcom

Riverside House

2a Southwark Bridge Road

London SE1 9HA

Tel: +44 (0)300 123 3333 or 020 7981 3040

Fax: +44 (0)20 7981 3333

information.requests@ofcom.org.uk

European Communications Office (ECO)

Peblingehus

Nansensgade 19

DK 1366 Copenhagen

Tel. +45 33896300

Fax +45 33896330

ero@ero.dk

www.ero.dk
